



www.gomacamps.com

España

(+34) 977 876 802
info@gomacamps.com

France

(+33) 563 358 905
france@fr.gomacamps.com

Portugal

(+351) 249 730 230
portugal@pt.gomacamps.com

Maroc

(+212) 0 5377 17774
maroc@ma.gomacamps.com

International

(+34) 977 876 803
export@gomacamps.com



Número Capas
Nombre de Plis
Número Folhas
Number of Plies



Número Servicios
Nombre de formats
Número Serviços
Number Services



Metros
Mètres
Metros
Meters



Rollos Paquete
Rouleaux x paquets
Pacote de Rolos
Rolls x Pack



Unidades Saco / Caja
Unités Sac / Boîte
Unidades Saco/Caixa
Units Sack / Box



Unidades Palet
Unités Palette
Unidades Palet
Units Pallet



Unidades Paquete
Unités Paquet
Unidades Pacote
Units Package



Diametro Mandril
Diamètre Mandrin
Diâmetro Mandril
Mandrel Diameter



Mandril extraíble
Mandrin extractible
Mandril removível
Removable mandrel



Ancho
Laize
Largura
Width



Panel
Panneau
Painel
Panel



Cerradura
Serrure
Bloqueio
Lock



Kangur
Kangourou
Kangur
Kangur



Servilleta 1/6, 1/8
Serviette 1/6, 1/8
Guardanapos 1/6, 1/8
Napkins 1/6, 1/8



Servilleta 1/4
Serviette 1/4
Guardanapos 1/4
Napkins 1/4



Servilleta Dispenser
Serviette Distributeur
Guarda. Dispenser
Napkins Dispenser



Rollo Mantel
Rouleaux de nappe
Rolos de Toalhas
Tablecloths Rolls



Suave
Doux
Suave
Soft



Dispersión fib as
Dispersion de la fibr
Dispersão de fib a
Fiber dispersion



Resistencia
Résistance
Resistência
Resistance



Extra Resistencia
Extra Résistance
Extra Resistência
Extra Resistance



Absorción
Absorption
Absorção
Absorption



Sin pelusa
Ne peluche pas
Sem fiapo
Lint-free



Antibacterial
Antibactérien
Antibacteriano
Antibacterial



Resistente al calor
Résistant à la chaleur
Resistente ao calor
Heat-resistant



Resistente a disolventes
Résistant aux solvants
Resistente a solventes
Resistant to solvents



Lavable en lavadora
Lavable en machine
Lavável na máquina
Machine washable



Resistente y flexi le
Résistant et flexi le
Resistente e flexi el
Resistant and flexi le



Contacto alimentario
Contact alimentaire
Contato com alimentos
Food Contact



Te recomendamos
Nous vous recommandons
Te recomendamos
We recommend you



Personalizadas
Personnalisés
Personalizados
Customized



Mantel
Sets de table
Toalhetes
Tablecloths

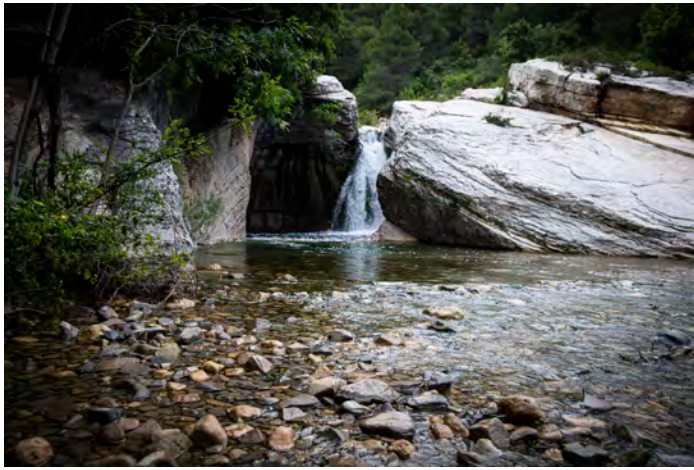

ES. Este 2021 se ha definido el Plan Estratégico del Grupo para los próximos años y se ha alineado la nueva Misión, Visión y los Valores del Grupo con un mayor compromiso con la sociedad. En línea con este compromiso, en 2022 ponemos en marcha nuestro primer Plan Estratégico de RSC y Sostenibilidad. De esta manera nos comprometemos con los retos globales y nos alineamos con los Objetivos de Desarrollo Sostenible (ODS) de las Naciones Unidas. En este compromiso, elegimos aquellos ODS en los que creemos tener más impacto para centrar nuestros esfuerzos y maximizar nuestra contribución.

NUEVA MISIÓN, VISIÓN Y VALORES

NUESTRA MISIÓN

Queremos ser el referente en el sector del papel tisú a través del reciclado, de la diferenciación y la excelencia, garantizando un crecimiento sostenible.

NUESTRA VISIÓN

Contribuir al reto colectivo de mejorar el mundo innovando y ofreciendo soluciones de higiene cotidianas que cuidan a las personas y al planeta.

NUESTROS VALORES

Integridad y compromiso. Honestidad, respeto y responsabilidad, fomentando la igualdad de todas las personas. Excelencia e ilusión. Entusiasmo en todo lo que hacemos para mejorar continuamente la satisfacción de los clientes, la optimización de los recursos y la calidad de nuestros productos. Sostenibilidad y proximidad. Promover el crecimiento, el desarrollo y el progreso presente sin comprometer los recursos futuros de nuestro entorno.

Innovación y colaboración. Aportar soluciones que respondan a las necesidades de las personas y el mercado promoviendo la cultura colaborativa.

FR. En 2021 nous avons défini le Plan Stratégique du Groupe pour les années à venir ainsi que les nouvelles Mission, Vision et Valeurs du Groupe qui démontrent notre engagement envers la société. Conformément à cet engagement, nous lancerons en 2022 notre premier plan stratégique RSE et développement durable. En agissant ainsi, nous nous engageons à relever les défis mondiaux en nous alignant sur les objectifs de développement durable (ODD) des Nations Unies. Nous avons choisi les objectifs à impact majeur afin de concentrer nos efforts et optimiser notre contribution.

NOUVELLE VISION, MISSION ET VALEURS

NOTRE MISSION

Être le référent dans le secteur du papier tissu avec nos produits recyclés, la différenciation et l'excellence, en garantissant une croissance durable.

NOTRE VISION

Contribuer au défi collectif en offrant des solutions d'hygiène quotidiennes qui prennent soin des personnes et de la planète afin d'améliorer le monde en innovant

NOS VALEURS

Intégrité et engagement. Honnêteté, respect et responsabilité en promouvant l'égalité pour tous. Excellence et enthousiasme. Enthousiasme dans tout ce que nous faisons afin d'améliorer quotidiennement la satisfaction de nos clients, l'optimisation de nos ressources et la qualité de nos produits. Développement durable et proximité. Promouvoir la croissance, le développement et le progrès sans compromettre les ressources futures de notre environnement. Innovation et collaboration. Apporter des solutions qui répondent aux besoins des individus et du marché en promouvant une culture collaborative.

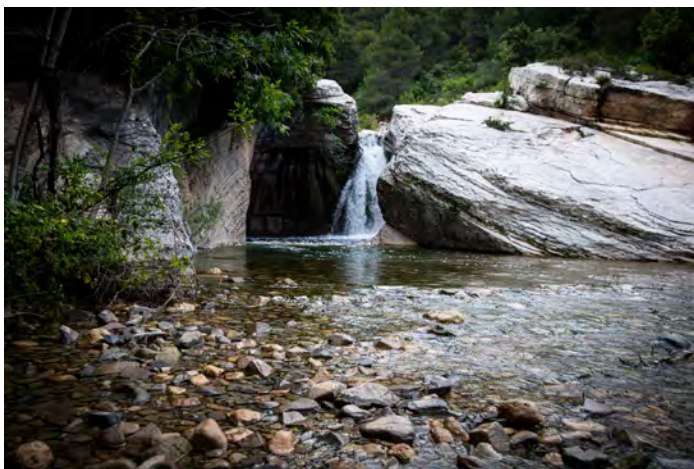

PT. Neste 2021 foi definido o Plano Estratégico do Grupo para os próximos anos e a nova Missão, Visão e Valores do Grupo foram alinhados com um maior compromisso com a sociedade. Em linha com este compromisso, lançaremos em 2022 o nosso primeiro Plano Estratégico de RSE e Sustentabilidade. Dessa forma, comprometemo-nos com os desafios globais e alinhamo-nos com os Objetivos de Desenvolvimento Sustentável (ODS) das Nações Unidas. Nesse compromisso, escolhemos os ODS nos quais acreditamos terem maior impacto para focar os nossos esforços e maximizar a nossa contribuição.

NOVA VISÃO, MISSÃO E VALORES

A NOSSA MISSÃO

Queremos ser a referência no sector do papel tissue através da reciclagem, da diferenciação e da excelência, garantindo um crescimento sustentável.

A NOSSA VISÃO

Contribuir para o desafio colectivo de melhorar o planeta, inovando e oferecendo soluções de higiene quotidianas que cuidam das pessoas e da natureza.

OS NOSSOS VALORES

Integridade e compromisso. Honestidade, respeito e responsabilidade, fomentando a igualdade de todas as pessoas.

Excelência e empenho. Entusiasmo em tudo o que fazemos para melhorar continuamente a satisfação dos clientes, a optimização dos recursos e a qualidade dos nossos produtos. Sustentabilidade e proximidade. Promover o crescimento, o desenvolvimento e o progresso presente sem comprometer os recursos ambientais futuros. Inovação e colaboração. Oferecer soluções que respondam às necessidades das pessoas e do mercado promovendo a cultura colaborativa.

EN. In 2021 the group strategic plan for the coming years was drawn up, and the group's mission, vision and values were aligned with a greater commitment to society. In line with this commitment, in 2022 we are setting up our first strategic CSR and sustainability plan. Like this we are making a commitment to global challenges and aligning ourselves with the United Nations Sustainable Development Goals (SDG). Under this commitment, we choose the SDGs where we believe we have the greatest impact in order to focus our efforts and maximise our contribution.

NOVA VISÃO, MISSÃO E VALORES

A NOSSA MISSÃO

Queremos ser a referência no sector do papel tissue através da reciclagem, da diferenciação e da excelência, garantindo um crescimento sustentável.

A NOSSA VISÃO

Contribuir para o desafio colectivo de melhorar o planeta, inovando e oferecendo soluções de higiene quotidianas que cuidam das pessoas e da natureza.

OS NOSSOS VALORES

Integridade e compromisso. Honestidade, respeito e responsabilidade, fomentando a igualdade de todas as pessoas.

Excelência e empenho. Entusiasmo em tudo o que fazemos para melhorar continuamente a satisfação dos clientes, a optimização dos recursos e a qualidade dos nossos produtos. Sustentabilidade e proximidade. Promover o crescimento, o desenvolvimento e o progresso presente sem comprometer os recursos ambientais futuros. Inovação e colaboração. Oferecer soluções que respondam às necessidades das pessoas e do mercado promovendo a cultura colaborativa.

GOMÀ-CAMPS GROUP :



138 mill. €

Cifra de facturación
Chiffre d'affaires
Cifra de facturação
Annual turnover



450 people

Equipo humano
Équipe humaine
Equipa humana
Human team



100.000 ton

Capacidad de transformación anual
Capacité de transformation annuelle
Capacidade de transformação anual
Annual processing capacity



1.200 Customers

Clients
Clients
Clientes
Customers



95.000 ton

Capacidad fabricación papel tisú
Capacité de fabrication de papier tissu
Capacidade de fabrico de papel tissue
Tissue paper production capacity



Brands

Marcas propias y para la distribución
Marques propres et pour la distribution
Marcas próprias e para a distribuição
Own brands and for distribution

Empresa certificada / Certified company



Certificados de producto / Product Certificates



Ask for products FSC® certificates

CERTIFICADOS Y GARANTÍAS DE CALIDAD:

Distintos certificados avalan el compromiso y respeto por el medioambiente de Gomà-Camps. Nuestro sistema de gestión y nuestros procesos de fabricación están certificados según la norma ISO 14001, e integrados al Sistema de Gestión de Calidad ISO 9001.

En 2008, Gomà-Camps fue la primera compañía de la península Ibérica del sector tisú en obtener la etiqueta Ecolabel.

Nuestros productos cuentan también con el certificado FSC®. El distintivo significa que la materia prima utilizada proviene de fuentes responsables y certificadas por FSC®. Entidad sin ánimo de lucro que promueve la gestión sostenible de los bosques y de las fuentes de papel reciclado para conseguir un equilibrio social, económico y medioambiental. También hemos incorporado la etiqueta FSC Recycled que nos indica que nuestros productos de tisú reciclado contienen material 100% reciclado.

La Certificación ISO 22.000 acredita que Gomà-Camps cumple el Sistema de Gestión de la Seguridad Alimentaria. Todos nuestros productos de mesa e higiene están certificados y cumplen esta normativa. Además nuestros productos están testados dermatológicamente.

ISO 50001 integra la Gestión de la energía en todos sus aspectos, dentro de una organización con el sistema de Gestión de la Empresa, abarcando desde la compra de energía y materias primas hasta las medidas a adoptar en la empresa para promover el ahorro energético.

El certificado Residuo Cero reconoce a las empresas que apuestan por la sostenibilidad como marco estratégico para el desarrollo de su actividad y que valorizan las distintas fracciones de los residuos que generan (más del 90%), evitando que estos tengan como destino final su eliminación en vertedero.

CERTIFICATS ET GARANTIES DE QUALITÉ :

Différents certificats garantissent l'engagement et le respect de l'environnement de Gomà-Camps. Notre système de gestion et nos processus de fabrication sont certifiés ISO 14001 et intégrés au système de gestion de la qualité ISO 9001.

En 2008, Gomà-Camps a été la première entreprise de la péninsule Ibérique du secteur des tissus à obtenir la certification écologique européenne Ecolabel.

Nos produits sont également certifiés FSC®. La certification signifie que la matière première utilisée provient de sources responsables et certifiées FSC®. Organisation à but non lucratif qui promeut la gestion durable des forêts et des sources de papier recyclé pour atteindre un équilibre social, économique et environnemental. Nous avons également intégré le label FSC Recycled qui indique que nos produits en papier recyclé contiennent 100% de matériaux recyclés.

La certification ISO 22 000 certifie que Gomà-Camps est conforme au système de gestion de la sécurité alimentaire. Tous nos produits de table et d'hygiène sont certifiés et respectent ces réglementations.

De plus, nos produits sont testés dermatologiquement.

ISO 50001 intègre la gestion de l'énergie dans tous ses aspects, au sein d'une structure utilisant le système de Gestion de l'Entreprise, allant de l'achat d'énergie et de matières premières aux mesures à adopter dans l'entreprise pour favoriser les économies énergétiques.

La norme Zéro Déchet fait partie du modèle d'économie circulaire dont l'objectif est d'inverser la pyramide actuelle basée sur le concept d'utilisation et d'élimination et d'ainsi passer à un modèle qui favorise la réduction, la réutilisation, le recyclage et la valorisation. L'idée est que chaque déchet d'un processus peut être une matière première pour un autre, maximisant la valeur des matières premières, augmentant les économies énergétiques et réduisant les émissions de gaz à effet de serre. Ce ne sont que les prémices de notre stratégie commerciale et de notre engagement en faveur du développement durable.

GOMÀ-CAMPS GROUP :



138 mill. €

Cifra de facturación
Chiffre d'affaires
Cifra de facturação
Annual turnover



450 people

Equipo humano
Équipe humaine
Equipa humana
Human team



100.000 ton

Capacidad de transformación anual
Capacité de transformation annuelle
Capacidade de transformação anual
Annual processing capacity



1.200 Customers

Cientes
Clients
Clientes
Customers



95.000 ton

Capacidad fabricación papel tisú
Capacité de fabrication de papier tissu
Capacidade de fabrico de papel tissue
Tissue paper production capacity



Brands

Marcas propias y para la distribución
Marques propres et pour la distribution
Marcas próprias e para a distribuição
Own brands and for distribution

Empresa certificada / Certified company



Certificados de producto / Product Certificates



The mark of responsible forestry
Ask for products FSC® certificates

CERTIFICADOS E GARANTIAS DA QUALIDADE:

Diferentes certificados garantem o compromisso e o respeito pelo meio ambiente por parte da Gomà-Camps. O nosso sistema de gestão e os nossos processos de fabricação são certificados de acordo com a ISO 14001 e integrados ao sistema de gestão de qualidade ISO 9001.

Em 2008, a Gomà-Camps foi a primeira empresa na Península Ibérica do sector de tissue a obter o rótulo ecológico europeu.

Os nossos produtos também possuem o certificado FSC®. O logo significa que a matéria-prima utilizada é proveniente de fontes responsáveis e certificadas pelo FSC®. Organização sem fins lucrativos que promove o manejo sustentável de florestas e fontes de papel reciclado para alcançar um equilíbrio social, económico e ambiental. Também incorporamos a etiqueta Reciclada FSC, que indica que nossos produtos de papel reciclado contêm 100% de material reciclado.

A certificação ISO 22.000 certifica que a Gomà-Camps está em conformidade com o Sistema de Gerenciamento de Segurança de Alimentos. Todos os nossos produtos de mesa e higiene são certificados e estão em conformidade com esses regulamentos.

Além disso, os nossos produtos são testados dermatologicamente.

A ISO 50001 integra a Gestão de Energia em todas as suas vertentes, dentro de uma organização com o sistema de Gestão da Empresa, desde a compra de energia e matéria-prima até às medidas a serem adoptadas na empresa para promover a poupança energética.

O certificado Resíduos Zero reconhece as empresas que apostam na sustentabilidade como quadro estratégico para o desenvolvimento da sua actividade e que valorizam as diferentes fracções dos resíduos que geram (mais de 90%), evitando que estes tenham como destino final a sua eliminação em aterros sanitários.

QUALITY CERTIFICATES AND GUARANTEES:

Different certificates guarantee the commitment and respect for the environment of Gomà-Camps. Our management system and our manufacturing processes are certified according to ISO 14001 and integrated into the ISO 9001 Quality Management System.

In 2008, Gomà-Camps was the first company in the Iberian Peninsula of the tissue sector to obtain the Ecolabel European Ecolabel.

Our products also have the FSC® certificate. The badge means that the raw material used comes from sources responsible and certified by FSC®. Non-profit organization that promotes the sustainable management of forests and recycled paper sources to achieve a social, economic and environmental balance. We have also incorporated the FSC Recycled label that indicates that our recycled tissue products contain 100% recycled material.

The ISO 22,000 Certification certifies that Gomà-Camps complies with the Food Safety Management System. All our table and hygiene products are certified and comply with these regulations.

In addition our products are dermatologically tested.

ISO 50001 integrates the Energy Management in all its matters, within an organization, with the Management Company System, covering from the purchase of energy and raw materials to the measures to be adopted in the company to promote energy savings.

The Zero Waste certificate recognizes companies that are committed to sustainability as a strategic framework for the development of their activity and that value the different fractions of the waste they generate (more than 90%), avoiding that these have as their final destination their disposal in dump.

Index

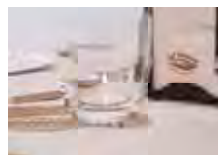

10-11

Nuestro papel reciclado / Notre papier recyclé.
Nosso papel reciclado / Our recycled paper.

12

Nuevos envases / Nouvel emballage
Nova embalagem / New packaging

Higiene y Limpieza / Hygiène et Nettoyage Higiene e Limpeza / Hygiene and Cleaning

13-16

Papel higiénico / Hygiéniques domestiques
Papel higiénico / Toilet paper

18-22

Higiénico industrial / Papier toilette industriel
Higiénico industrial / Industrial toilet paper

23-29

Secamanos / Maxi-mains
Seca-mãos / Hand towel Roll

30-34

Celulosa Industrial / Bobine industrielle
Celulose Industrial / Industrial cellulose

35

Papel de Cocina / Essuie-tout ménager
Papel de Cozinha / Kitchen roll

36-39

Toallas de Mano / Essuie-mains enchevêtrés
Toalhas de Mão / Hand towels

40-41

Rollo papel Camilla / Drap d'examen
Rolo de papel Maca / Medical roll

42-43

Pañuelos y Faciales / Boîtes et paquets de mouchoirs
Lenços e Lenços faciais / Paper handkerchiefs and face tissues

44

Toallas desechables / Serviettes jetables
Toalhas descartáveis / Disposable towels

45-53

Paños no tejidos / Chiffons non-tissés
Panos não tecido / Non-cloth wipes

54-58

Dispensadores Higiene / Distributeurs Hygiéniques
Dispensadores de Higiene / Sanitary Dispensers

Para la Mesa / Pour la Table / Para a Mesa / For the Table

61-66

Servilletas Spunlace Collection / Serviettes Spunlace Collection
Guardanapos Spunlace Collection / Napkins Spunlace Collection

67-85

Servilletas y manteles Airlaid Collection / Serviettes et nappes Airlaid Collection
Guardanapos e toalhas de mesa Airlaid Collection / Napkins and tablecloths Airlaid Collection

86-87

Servilletas y manteles Nature / Serviettes et nappes Nature
Guardanapos e toalhas de mesa Nature / Napkins and tablecloths Nature

88-89

Servilletas GC ecologic+ / Serviettes GC ecologic+
Guardanapos GC ecologic+ / Napkins GC ecologic+

90-92

Mantelería GC ecologic + / Nappage GC ecologic +
Conjuntos de Mesa GC ecologic + / GC ecologic + Tablecloths

93-98

Servilletas GC / Serviettes GC
Guardanapos GC / GC Napkins

99-100

Mantelería DCR / Nappage DCR
Conjuntos de Mesa DCR / DCR Tablecloths

101-102

Personalizaciones / Personnalisé
Personalizados / Customized

103-104

Dispensadores de Mesa / Distributeurs de Table
Dispensadores de Mesa / Table Dispensers



ES "Hoy, más que nunca, el Grupo Gomà-Camps está comprometido con el medio ambiente. Por eso, este 2021 lo hemos querido plasmar en nuestra nueva Misión, Visión y Valores. Las personas que formamos parte de esta gran familia, queremos convertirnos en tu referente de papel tisú a través del reciclado, de la diferenciación y la excelencia, teniendo en cuenta un crecimiento sostenible. Comprometid@s con nuestro papel es nuestro lema y en este catálogo te mostramos los productos más excelentes para tu negocio. Es la primera vez que tengo el placer de presentártelo como Directora General y me enorgullece mostrarte la gran variedad de gama y productos innovadores. Nuestra organización sigue siendo una empresa dinámica, innovadora y comprometida con la sostenibilidad. Desde Gomà-Camps tratamos de contribuir al reto colectivo de mejorar el mundo innovando y ofreciendo soluciones de higiene cotidianas que cuidan a las personas y al planeta. ¿Nos acompañas?"

PT "Hoje, mais do que nunca, o Grupo Gomà-Camps está comprometido com o meio ambiente. Por isso, neste 2021, quisemos projetá-lo na nossa nova Missão, Visão e Valores. As pessoas que fazem parte desta grande família querem converter-se no seu referente em papel tissue através do reciclado, da diferenciação e da excelência, tendo em conta o crescimento sustentável. Comprometidos com o nosso papel é o nosso lema e neste catálogo apresentamos-lhe produtos de excelência para o seu negócio. É a primeira vez que tenho o prazer de apresentá-lo a si como Diretora Geral e tenho orgulho de mostrar a ampla variedade de produtos inovadores. A nossa organização continua a ser uma empresa dinâmica, inovadora e comprometida com a sustentabilidade. Na Gomà-Camps procuramos contribuir para o desafio coletivo de melhorar o mundo, inovando e oferecendo diariamente soluções de higiene que cuidam das pessoas e do planeta. Pode acompanhar-nos?"

FR "« Aujourd'hui, plus que jamais, le Groupe Gomà-Camps s'engage pour l'environnement. Pour cette raison, cette année 2021 a été caractérisée par nos nouvelles Mission, Vision et Valeurs. Les personnes qui font partie de cette grande famille souhaitent devenir votre référence en matière de papier tissu grâce au recyclage, la différenciation et l'excellence, en tenant compte d'un développement et une croissance durable. "Engagés avec notre papier" est notre devise et dans ce catalogue nous avons choisi de vous montrer les meilleurs produits pour votre entreprise. C'est la première fois que j'ai le plaisir de vous les présenter, en tant que Directeur Général, et je suis fier de vous montrer la grande variété de gamme et de produits innovants. Nous sommes toujours une entreprise dynamique et innovante engagée envers la durabilité. Chez Gomà-Camps, nous essayons de contribuer au défi collectif d'améliorer le monde en innovant et en proposant des solutions d'hygiène qui prennent soin des personnes et de la planète. Voulez-vous nous rejoindre?"

EN "Today more than ever the Gomà-Camps group is committed to the environment. This is why in 2021 we wanted to make this clear in our new mission, vision and values. The people who make up this big family want to become your point of reference for tissue paper through recycling, differentiation and excellence, taking into account sustainable growth. Our slogan is "comprometid@s con nuestro papel", which in Spanish means committed both to our paper and to our role in society, and this catalogue contains the most excellent products for your business. This is the first time I have had the pleasure of presenting it as General Manager and I am proud to be able to show you our widely varied range and innovative products. Our organisation remains a dynamic, innovative company, committed to sustainability. At Gomà-Camps we try to contribute to the collective challenge of making the world a better place by innovating and offering everyday hygiene solutions that care for people and for the planet. Are you with us?"

Laia Gomà-Camps, CEO

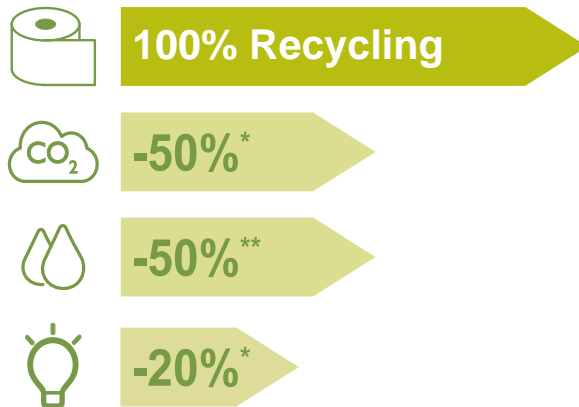

*Calculations made throughout the product life cycle.
** Data compared to the sector average.

Nuestro reciclado, comprometido con el medio ambiente

+ 100% RECICLADO

Utilizamos papel recuperado como materia prima. Las fibras de celulosa se pueden reutilizar hasta 7 veces, alargando su ciclo de vida.

Impulsamos la economía circular.

+ SOSTENIBLE

Reducimos las emisiones de CO₂ y optimizando nuestros consumos de agua y energía.

No utilizamos sustancias químicas peligrosas.

Minimizamos y valorizamos los residuos de nuestro proceso.

Utilizamos plástico reciclado y reciclable en nuestros embalajes y en otros casos lo eliminamos.

+ ECOLÓGICO

Usamos papel reciclado en productos de un solo uso contribuyendo a la protección del medio ambiente.

Fomentamos los formatos de gran contenido para optimizar transporte y almacenaje.



En 2021 hemos reducido en un 54,6%* el plástico virgen en los embalajes.

*Datos internos 2021 acumulado septiembre. Canal profesional.

Notre recyclé, un engagement envers la préservation de l'environnement

+ 100% RECYCLE

- Nous utilisons du papier recyclé comme matière première.
- Les fibres de cellulose peuvent être réutilisées jusqu'à 7 fois, ce qui rallonge leur cycle de vie.
- Nous impulsions l'économie circulaire.

+ DURABLE

- Nous réduisons les émissions de CO₂ et nous optimisons notre consommation d'eau et d'énergie.
- Nous n'utilisons pas de substances chimiques dangereuses.
- Nous minimisons et valorisons les déchets issus de notre processus de fabrication.
- Nous utilisons du plastique recyclé et recyclable dans nos emballages et dans d'autres cas nous l'éliminons.

+ ECOLOGIQUE

- Nous utilisons du papier recyclé dans nos produits à usage unique en contribuant ainsi à la protection de l'environnement.
- Nous promovons les formats de grande contenance.



En 2021, nous avons réduit le plastique vierge dans les emballages de 54,6 %*.

*Données internes 2021 (cumul fin septembre). Canal professionnel.

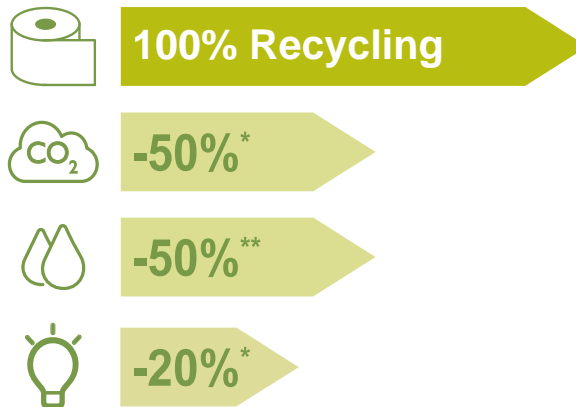

*Calculations made throughout the product life cycle.
** Data compared to the sector average.

O nosso reciclado, comprometido com o meio ambiente

+ 100% RECICLADO

- Utilizamos papel recuperado como matéria-prima.
- As fibras de celulose podem reutilizar-se até 7 vezes, alargando assim o seu ciclo de vida.
- Fomentamos a economia circular.

+ SUSTENTÁVEL

- Reduzimos as emissões de CO₂ e otimizando os nossos consumos de água e energia.
- Não utilizamos substâncias químicas perigosas.
- Minimizamos e valorizamos os resíduos do nosso processo.
- Utilizamos plástico reciclado e reciclável nas nossas embalagens e em outros casos foi eliminado.

+ ECOLÓGICO

- Usamos papel reciclado em produtos de utilização única contribuindo para a proteção do meio ambiente.
- Fomentamos os formatos de grande conteúdo para otimizar o transporte e armazenamento.



Em 2021, reduzimos o plástico virgem nas embalagens em 54,6%*.

*Dados internos 2021 acumulados em setembro. Canal profissional.

Our recycling process, committed to the environment

+ 100% RECYCLED

- We use recovered paper as raw material.
- Cellulose fibers can be reused up to 7 times, thus extending their life cycle.
- We promote circular economy.

+ SUSTAINABLE

- We reduce CO₂ emissions and optimize our water and energy consumption.
- We do not use dangerous chemicals.
- We minimize and value the waste from our processes.
- We use recycled and reusable plastic in our packaging.

+ ECOLOGICAL

- We use recycled paper in single-use products, contributing to the protection of the environment.
- We promote large-formats to optimize transport and storage.



In 2021 we reduced the virgin plastic in our packaging by 54.6%*.

*Internal figures for 2021 accumulated as of September. Professional channel.

Reducimos en un 34,4% el plástico virgen en los embalajes del grupo GC

■ Durante el 2021, reducimos el impacto ambiental en los envases para ayudar a nuestros clientes en sus objetivos de sostenibilidad.

■ El 100% de los plásticos utilizados son reciclables.

■ En los palets utilizamos un nuevo film estirable que mantiene el mismo rendimiento logístico, y nos permite reducir un 50% el plástico utilizado.

■ En los embalajes de los higiénicos domésticos eliminamos las asas y utilizamos 50% plástico reciclado y 50% plástico virgen.

■ En Láminas saco utilizamos 70% plástico reciclado y 30% plástico virgen.

■ En lo pañuelos faciales eliminamos el plástico de la solapa.

■ En los embalajes de la gama de mesa apostamos por nuevos materiales compostables y reciclados.

■ Las cajas que utilizamos son de cartón 100% reciclado.

Reduzimos em 34,4% o plástico virgem nas embalagens do grupo GC

■ En 2020, nous réduisons l'impact environnemental sur les emballages pour aider nos clients dans leurs objectifs de durabilité.

■ 100% des plastiques utilisés sont recyclables.

■ Pour les palettes, nous utilisons un nouveau film étirable qui maintient les mêmes performances logistiques et nous permet de réduire de 50% le plastique utilisé.

■ Dans les emballages de nos papiers hygiéniques domestiques, nous retirons les poignées et utilisons 50% de plastique recyclé et 50% de plastique vierge.

■ Pour les films des colis, nous utilisons 70% de plastique recyclé, 30% de plastique vierge.

■ Dans les mouchoirs, nous retirons le plastique du rabat.

■ Dans l'emballage de la gamme de tables, nous misons sur de nouveaux matériaux compostables et recyclés.

■ Les boîtes que nous utilisons sont en carton 100% recyclé.

Nous avons réduit le plastique vierge dans les emballages du groupe GC de 34,4 %

■ Em 2020, reduzimos o impacto ambiental nas embalagens para ajudar os nossos clientes nos seus objetivos de sustentabilidade.

■ 100% dos plásticos utilizados são recicláveis.

■ Nas paletes, usamos uma nova película elástica que mantém o mesmo desempenho logístico e permite reduzir o plástico usado em 50%.

■ Nas embalagens higiénicas domésticas, removemos as alças e usamos 50% de plástico reciclado e 50% de plástico virgem.

■ Nos sacos, usamos 70% de plástico reciclado, 30% de plástico virgem.

■ Nos lenços faciais, removemos o plástico da abertura..

■ Nas embalagens de guardanapos usamos 50% de plástico reciclado.

■ Na embalagem da gama de mesas, apostamos em novos materiais compostáveis e reciclados.

We reduce virgin plastic in GC group packaging by 34.4%

■ During 2020 we reduce the environmental impact on packaging to help our customers in their sustainability objectives.

■ 100% of the used plastics are recyclable.

■ In the pallets we use a new stretch film that maintains the same logistic performance and allows us to reduce the plastic used by 50%.

■ In household hygienic packaging we remove the handles and use 50% recycled plastic and 50% virgin plastic.

■ In bag films we use 70% recycled plastic, 30% virgin plastic.

■ In the facial tissues we remove the plastic from the flap.

■ In the packaging of the table range we bet on new compostable and recycled materials.

■ The boxes we use are 100% recycled cardboard.



Higiene y Limpieza
 Hygiène et Nettoyage
 Higiene e Limpeza
 Hygiene and Cleaning



HIGIÉNICO DOMÉSTICO

Suavidad y dispersión garantizada.

HYGIENIQUES DOMESTIQUES

Douceur et dispersion garantie.

HIGIÉNICO DOMÉSTICO

Maciez e dispersão garantida.

DOMESTIC HYGIENE

Softness and guaranteed dispersion.

HIGIÉNICO DOMÉSTICO / HYGIENIQUES DOMESTIQUES

HIGIÉNICO DOMÉSTICO / TOILET PAPER



100% FIBRAS RECICLADAS · 100% FIBRES RECYCLÉES · 100% FIBRAS RECICLADAS · 100% RECYCLED FIBERS

ES Los rollos higiénicos domésticos GCecologic+ son 100% reciclados blancos, ecológicos y certiAcados. Ofrecen gran suavidad y blancura.

FR Les rouleaux de papiers toilettes domestiques GCecologic+ sont 100 % recyclés, blancs, écologiques et certiAcés.

PT Os rolos de higiénico doméstico GCecologic+ são 100% reciclados brancos, ecológicos e certiAcados.

EN GCecologic+ toilet paper roll for domestic use are 100% recycled, environmentally-friendly and certiAced.



**SUAVE
DOUX
SUAVE
SOFT**

The mark of responsible forestry



Suave
Doux · Soft



Dispersión
Dispersion · Dispersão



H263370

H263393

H263360

H263380

H263302

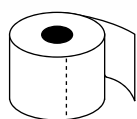

Higiénico Doméstico
Hygiénique Domestique
Higiénico Doméstico
Toilet paper



		n°	n°	m	Rolls x Pack	Rolls x Bag	Bags x Pallet
H263370	GC ecologic+ 140	2	140	14	12	108	26
H263380	GC ecologic+ 180	2	180	18	12	108	26
H263393	GC ecologic+ 200	2	200	22,4	12	108	26
H263337	GC ecologic+ 300 LT	2	300	34,5	12	96	26
H263302	GC ecologic+ 300	2	300	34,5	12	96	26
H263360	GC ecologic+ 500	2	500	50	6	30	63



ES El exclusivo gofrado ConforDeco del higiénico doméstico garantiza una óptima unión de las capas y una gran suavidad.

FR Le gaufrage exclusif ConforDeco du papier toilette domestique garantit une union optimale des plis et une grande douceur.

PT A exclusiva gofragem ConforDeco do higiénico doméstico garante uma óptima união das camadas e uma grande maciez.

EN The exclusive embossed design of our ConforDeco toilet paper guarantees optimal ply bonding and excellent softness.

HIGIÉNICO DOMÉSTICO / HYGIENIQUES DOMESTIQUES

HIGIÉNICO DOMÉSTICO / TOILET PAPER



100% FIBRAS RECICLADAS · 100% FIBRES RECYCLÉES · 100% FIBRAS RECICLADAS · 100% RECYCLED FIBERS

ES Los rollos GC Nature son 100% reciclados con fibras de celulosa presentes en el cartón, y facilitan la visibilidad de la sostenibilidad.

FR Les rouleaux GC Nature sont 100% recyclés avec des fibres de cellulose présentes dans le carton, et facilitent la visibilité de la durabilité.

PT Os rolos GC Nature são 100% reciclados com fibras de celulosa presentes no papelão, facilitando a visibilidade da sustentabilidade.

EN GC Nature rolls are made from 100% recycled cellulose fibers present in cardboard. They facilitate the visibility of sustainability.



H263343



Suave
Doux · Soft



Dispersión
Dispersion · Dispersão

ConforDeco®

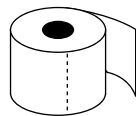

Higiénico Doméstico
Hygiénique Domestique
Higiénico Doméstico
Toilet paper

	n°	n°	m	Rolls x Pack	Rolls x Bag	Bags x Pallet
H263343 GC Nature 300	2	300	34,5	12	96	26

HIGIÉNICO DOMÉSTICO / HYGIENIQUES DOMESTIQUES

HIGIÉNICO DOMÉSTICO / TOILET PAPER



100% CELULOSA VIRGEN · 100% PURE PÂTE · 100% CELULOSE VIRGEM · 100% VIRGIN CELLULOSE

ES Papel higiénico de gran calidad, 4 capas, extrasuave, resistente y con servicios XL. Fácil de transportar; bolsa de 8 rollos.

FR Papier toilette de grande qualité, 4 plis, extra doux, résistant et avec des formats XL. Facile à transporter; paquet de 8 rouleaux.

PT Papel Higiénico de grande qualidade, 4 camadas, extra-macio, resistente e com serviços XL. Fácil de transportar; saco de 8 rolos.

EN High-quality, 4-ply toilet paper: extra-soft, strong, XL size. Easy to transport in 8 rolls bag.



Extra Suave
Extra Doux · Extra Soft



Dispersión
Dispersion · Dispersão

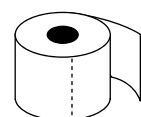

Higiénico Doméstico
Hygiénique Domestique
Higiénico Doméstico
Toilet paper

	n°	n°	m	Rolls x Pack	Rolls x Bag	Bags x Pallet
H000190 GC PREMIUM 150, P8	4	150	19,5	8	72	21

100 % CELULOSA VIRGEN · 100% PURE PÂTE · 100% CELULOSE VIRGEM · 100% VIRGIN CELLULOSE

ES Amplia oferta en rollos higiénicos domésticos certificados de celulosa virgen de 2, 3 capas que se caracterizan por su suavidad y absorción.

FR Grand choix de rouleaux de papiers toilettes domestiques certifiés en pure pâte de 2, 3 plis qui se caractérisent par leur douceur et leur capacité d'absorption.

PT Vasta oferta em rolos de higiénico doméstico certificados, de celulose virgem de 2 e 3 camadas, que se caracterizam pela sua maciez e absorção.

EN A wide range of domestic toilet paper rolls made from certified virgin cellulose with 2, 3 ply characterized by their softness and absorption.



Suave
Doux · Soft



Dispersión
Dispersão · Dispersão



H263321



H263313



H263600



H263320



H263407



H287590



H287560

ConforDeco®

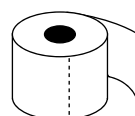

Higiénico Doméstico
Hygiénique Domestique
Higiénico Doméstico
Toilet paper

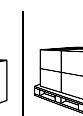
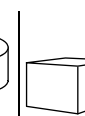
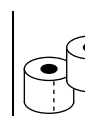
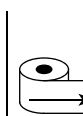
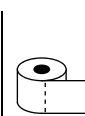

			n°	n°	m	Rolls x Pack	Rolls x Bag	Bags x Pallet
H287590	GC 140		2	140	14	4	108	26
H287560	GC 140		2	140	14	12	108	26
H263321	GC 180,		2	180	18	12	108	26
H263313	GC 200		2	200	22,4	12	108	26
H263600	GC 300		2	300	34,5	6	96	26
H263320	GC 500		2	500	50	6	30	63
H263407	GC 150		3	150	19	12	96	24



H303400

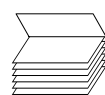

Hig. Doméstico Interplegado
Papier toil. domestique enchevêtré
Hig. Doméstico folha a folha
Interfolded domestic toilet paper



H303400	GC Interfolded 250		2	450	47,5	190x110	18	40
---------	--------------------	--	---	-----	------	---------	----	----

**Gofrado
de nubes,
25%* más suave**

**Gaufrage de
nuages,
25%* plus doux**

**Gofrado de
nuvens,
25%* mais suave**

**Clouds
embossing,
25%* softer**



Gracias a la nueva tecnología de unión de capas, el gofrado de nubes aporta un extra de suavidad en los higiénicos de 2, 3 y 4 capas.

Grâce à la nouvelle technologie d'union des plis, le gaufrage de nuages offre une douceur supplémentaire pour les papiers toilettes domestiques de 2, 3 et 4 plis.

Graças à nova tecnologia de união de folhas, o gofrado em nuvem oferece suavidade extra nos higiénicos de 2, 3 e 4 folhas.

Thanks to the new layer joining technology, cloud embossing provides extra softness in 2, 3 and 4 ply toilet rolls.

(*) Internal source: Handfeel calculation



Airports / Edificios públicos / Gares / Écoles / Stations / Public buildings / Estações de comboio

HIGIÉNICO INDUSTRIAL

Suavidad y dispersión garantizada. Ideal para espacios con mucha afluencia de personas.

PAPIER TOILETTE INDUSTRIEL

Douceur et dispersion garantie. Idéal pour les espaces avec beaucoup d'afluence.

HIGIÉNICO INDUSTRIAL

Suavidade e dispersão garantida. Ideal para espaços com muita afluência.

INDUSTRIAL TOILET PAPER

Softness and guaranteed dispersion. Ideal for crowded spaces.



HIGIÉNICO INDUSTRIAL / PAPIER TOILETTE INDUSTRIEL HIGIÉNICO INDUSTRIAL / JUMBO INDUSTRIAL TOILET PAPER



100% FIBRAS RECICLADAS · 100% FIBRES RECYCLÉES · 100% FIBRAS RECICLADAS · 100% RECYCLED FIBERS

ES Los rollos higiénicos industriales GC ecologic+ se caracterizan por su blancura, suavidad y dispersión. Además son 100% reciclados, ecológicos y están certificados

FR Les rouleaux de papiers toilettes industriels GCecologic+ se caractérisent par leur blancheur, douceur et dispersion. Ils sont 100% recyclés, écologiques et certifiés

PT Os rolos de higiénico industrial GC ecologic+ caracterizam-se pela sua brancura, maciez e dispersão. Além disso, são 100% reciclados, ecológicos e certificados

EN GC ecologic+ industrial toilet paper is characterized by its whiteness, softness and dispersion. What's more, it is 100% recycled, environmentally-friendly and certified



The mark of responsible forestry



Suave
Doux · Soft



Dispersión
Dispersion · Dispersão



J287310



J282300

Gofrado liso, 1 Capa Gaufrage lisse, 1 Pli Gofragem lisa, 1 Folha Smooth embossed, 1 Ply		Higiénico Industrial Papier toilette industriel Higiénico Industrial Industrial toilet paper										
										n°	Ø mm	Ø mm
	J287010	GC ecologic+ 250	1	173	45	1.250	250	18	40			
	J287310	GC ecologic+ 250	1	173	45	1.250	250	6	2x60			
			n°	Ø mm	Ø mm	n°	m	Units x bag	Bags x Pallet			
	NEW !	J287051	GC ecologic+ 100 LT	2	170	45	495	100	18	45		
		J282300	GC ecologic+ 124	2	175	45	620	124	18	45		
		J287090	GC ecologic+ 124	2	183	58	620	124	18	36		
	NEW !	J282302	GC ecologic+ 124 LT	2	170	45	620	124	18	45		
		J282310	GC ecologic+ 124	2	173	58	620	124	6	2x60		
		J287040	GC ecologic+ 161	2	205	45	805	161	12	48		
		J282500	GC ecologic+ 173,	2	200	45	865	173	18	32		
NEW !	J282501	GC ecologic+ 173 LT	2	200	45	868	173	18	32			
	J287089*	GC ecologic+ 190	2	203	45	730	190	12	40			

* Distribución Central / Distribution centrale / Dispensação Central / Central Dispensing

HIGIÉNICO INDUSTRIAL MAXI / PAPIER TOILETTE INDUSTRIEL MAXI HIGIÉNICO INDUSTRIAL MAXI / MAXI JUMBO INDUSTRIAL TOILET PAPER



100% FIBRAS RECICLADAS · 100% FIBRES RECYCLÉES · 100% FIBRAS RECICLADAS · 100% RECYCLED FIBERS



The mark of responsible forestry



Suave
Doux · Soft



Dispersion
Dispersion · Dispersão



J287120

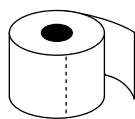

Higiénico Industrial Maxi
Papier toilette industriel Maxi
Higiénico Industrial Maxi
Maxi Jumbo Toilet Paper



n°

Ø mm

Ø mm

n°

m

Units x Bag

Bags x Pallet

J887116 GC ecologic+ 320

2

257

58

1.600

320

6

48

J287120 GC ecologic+ 380

2

257

58

1.900

380

6

48

Gofrado de bordes, 2 Capas
Gaufrage des bords, 2 Plis
Gofragem das extremidades, 2 Folhas
Embossed edges, 2 Ply



HIGIÉNICO INDUSTRIAL / PAPIER TOILETTE INDUSTRIEL HIGIÉNICO INDUSTRIAL / JUMBO INDUSTRIAL TOILET PAPER



100% FIBRAS RECICLADAS · 100% FIBRES RECYCLÉES · 100% FIBRAS RECICLADAS · 100% RECYCLED FIBERS

ES Los rollos GC Nature son 100% reciclados con fibras de celulosa presentes en el cartón, y facilitan la visibilidad de la sostenibilidad.

FR Les rouleaux GC Nature sont 100% recyclés avec des bres de cellulose présentes dans le carton, et facilitent la visibilité de la durabilité.

PT Os rolos GC Nature são 100% reciclados com fibras de celulosa presentes no papelão, facilitando a visibilidade da sustentabilidade.

EN GC Nature rolls are made from 100% recycled cellulose fibers present in cardboard. They facilitate the visibility of sustainability.



J283300

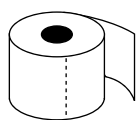

Higiénico Industrial
Papier toilette industriel
Higiénico Industrial
Industrial toilet paper

J283300

GC Nature 124

n°	Ø mm	Ø mm	n°	m	Units x bag	Bags x Pallet
2	175	45	620	124	18	45



100% CELULOSA VIRGEN · 100% PURE PÂTE · 100% CELOULOSE VIRGEM · 100% VIRGIN CELLULOSE

ES La marca GC ofrece una amplia oferta en rollos higiénicos industriales certificados de celulosa virgen, que se caracterizan por su suavidad y adsorción.

FR La marque GC offre une large gamme de rouleaux de papiers toilettes industriels certifiés en pure pâte qui se caractérisent par leur douceur et leur capacité d'absorption.

PT A marca GC oferece uma vasta oferta em rolos de higiénico industrial certificados de celulose virgem que se caracterizam pela sua maciez e absorção.

EN A wide range of industrial toilet paper rolls made from certified virgin cellulose characterized by their softness and absorption.



The mark of responsible forestry



Suave
Doux · Soft



Dispersión
Dispersion · Dispersão



J282510

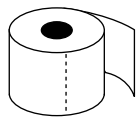

Higiénico Industrial
Papier toilette industriel
Higiénico Industrial
Industrial toilet paper



NEW!

		n°	Ø mm	Ø mm	n°	m	Units x bag	Bags x Pallet
J282330	GC 124	2	173	45	620	124	18	45
J282510	GC 173	2	200	45	865	173	18	32
J282410	GC 143 P 18	2	185	45	715	143	18	36

Dispensador / Distributeur / Dispensador / Dispenser

NEW!

100% Recycled



Dispensador Higiénico Industrial
Distributeur Papier toilette industriel
Dispensador Higiénico Industrial
Industrial Hygienic Dispenser



Ø 220 mm



Ø 45 mm



J288005	100% Recycled Plastic, white	Dispenser Size 274X270X115
---------	------------------------------	-------------------------------

6 U. x Box

Ideal para aseos con tránsito elevado. Diseño funcional, se adapta a cualquier espacio.
 Idéal pour les toilettes à forte fréquentation. Design fonctionnel, il s'adapte à tous les espaces.
 Ideal para casas de banho com elevada afluência. Design funcional, adapta-se a qualquer espaço.
 Ideal for toilets with high influx of people. Functional design suitable to all spaces.



SECAMANOS, PAPEL DE COCINA, CELULOSA INDUSTRIAL Y TOALLAS DE MANO:

La gama profesional más amplia de limpieza y secado de manos.

MAXI-MAINS, ESSUIE-TOUT MENAGER ET BOBINE INDUSTRIELLE

La gamme professionnelle la plus large de nettoyage et d'essuyage des mains.



SECA-MÃOS, PAPEL DE COZINHA, CELULOSE INDUSTRIAL E TOALHAS DE MÃO:

A gama profissional mais vasta para a limpeza e secagem das mãos.



HAND TOWEL ROLL, KITCHEN ROLL, INDUSTRIAL CELLULOSE AND HAND TOWELS:

The largest professional range of cleaning and hand drying products.

100% FIBRAS RECICLADAS · 100% FIBRES RECYCLÉES · 100% FIBRAS RECICLADAS · 100% RECYCLED FIBERS

ES Bobinas de celulosa reciclada y certificada con resistencia, absorción y blancura similares a la celulosa standard. Adecuado para la limpieza de entornos de trabajo profesionales de uso intensivo como talleres industriales.

FR Bobine en ouate recyclée et certifié, ayant une résistance, une absorption et une blancheur semblables à la ouate de cellulose standard. Appropriée pour le nettoyage de lieux de travail professionnels à usage intensif, tels que les ateliers industriels.

PT Bobina de celulose reciclada e certificada com resistência, absorção e brancura similares à da celulose padrão. Adequada para a limpeza de ambientes de trabalho profissionais de uso intenso como oficinas industriais.

EN Reel of recycled, certified cellulose tissue offering strength, absorbency and whiteness comparable to standard cellulose. Suitable for intensive use. To clean professional work environments such as industrial workshops.



J288423



Resistencia · Résistance
Resistência · Resistance

Absorción · Absorption
Absorção · Absorção

► Gofrado liso / Gaufrage lisse / Gofragem lisa / Plain embossing

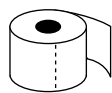

Secamanos
Maxi Mains
Seca-Mãos
Hand Towel Roll



		n°	Ø mm	Ø mm	n°	m	mm	Units x bag	Bags x Pallet
J288389	GC ecologic+ 285	1	200	76	814	285	200	6	48
J288210	GC ecologic+ 350	1	207	76	1.000	350	215	6	40

Gofrado liso
Gaufrage lisse
Gofragem lisa
Plain embossing

► Gofrado de bordes / Gaufrage des bords / Gofragem das extremidades / Edges embossing

		n°	Ø mm	Ø mm	n°	m	mm	Units x bag	Bags x Pallet
J288360	GC ecologic+ 135 ST	2	190	76	450	135	200	6	44
J288230	GC ecologic+ 150 ST	2	190	76	450	150	215	6	40
J288290	GC ecologic+ 150 ST	2	190	76	450	150	215	2	2X60
J288220	GC ecologic+ 180 ST	2	204	76	514	180	215	6	40
NEW !	J288866 GC ecologic+ 135 ST	2	190	78	443	135	184	6	52



Gofrado de bordes.
Gaufrage des bords.
Gofragem das extremidades.
Edges embossing.

► Gofrado ADD System / Gaufrage ADD System / Gofragem ADD System / ADD System embossing

		n°	Ø mm	Ø mm	n°	m	mm	Units x bag	Bags x Pallet
J288130	GC ecologic+ 46 MINI ST	2	120	45	125	46	200	12	55
J288144	GC ecologic+ 80 MINI ST	2	150	45	200	80	200	12	44
J288120	GC ecologic+ 80 MINI ST	2	155	45	40	80	200	12	44
NEW !	J288890 GC ecologic+ 94 LT ADD SYSTEM	2	184	76	400	94	184	6	52
J288850	GC ecologic+ 106 LT	2	185	76	450	106	200	6	44
J888451	GC ecologic+ 106 ST Multipurpose	2	190	76	450	106	200	1x6	44
J888450	GC ecologic+ 106 ST	2	190	76	450	106	200	6	44
NEW !	J288423 GCecologic+ 106 ST A	2	185	76	443	135	184	2x6	44
J288608	GC ecologic+ 143 LT	2	195	76	477	143	200	6	44
J288069	GC ecologic+ 170 LT	2	200	76	515	170	200	6	44



LT = Light / ST = Standard

SECAMANOS / MAXI MAINS SECA-MÃOS / HAND TOWEL ROLL

100% FIBRAS RECICLADAS · 100% FIBRES RECYCLÉES · 100% FIBRAS RECICLADAS · 100% RECYCLED FIBERS

ES Secamanos certificado, compuesto por fibras de celulosa 100% reciclada, presentes en los envases de cartón. Su color característico Nature transmite valores de respeto por el medio ambiente.

FR Essuie-mains certifié composé de fibres de ouate 100 % recyclée, présentes dans les emballages carton. Sa couleur caractéristique Nature transmet les valeurs de respect de l'environnement.

PT Seca-mãos certificado, composto por fibras de celulosa reciclada 100% presentes nas embalagens de cartão. A sua cor característica Nature transmite valores de respeito pelo meio ambiente.

EN Certified hand towel roll made from 100% recycled cellulose fiber obtained from cardboard packaging. The distinctive Nature color expresses values such as respect for the environment.



The mark of responsible forestry



Food Contact

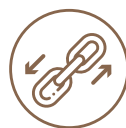
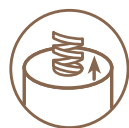

Resistencia · Resistance
Resistència · Resistance



Absorción
Absorption · Absorção



J288468

► Gofrado ADD System / Gaufrage ADD System / Gofragem ADD System / ADD System embossing

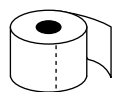

Secamanos
Maxi Mains
Seca-Mãos
Hand Towel Roll

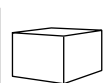
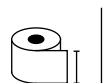
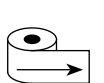
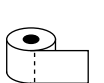
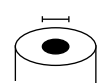
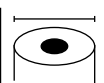

		n°	Ø mm	Ø mm	n°	m	mm	Units x bag	Bags x Pallet
J888465	GC Nature 106 ST	2	190	76	450	106	200	6	44
J288468	GC Nature 106 ST	2	190	76	450	106	200	2x6	44
J288613	GC Nature 143 ST	2	205	76	477	143	200	6	44

ST = Standard



100% CELULOSA VIRGEN · 100% PURE PÂTE · 100% CELOULOSE VIRGEM · 100% VIRGIN CELLULOSE

ES Bobina 100% celulosa virgen certificada que se caracteriza por su resistencia y absorción.

FR Bobine 100 % ouate vierge certifiée qui se caractérise par sa résistance et son absorption.

PT Bobina 100% celulose virgem certificada que se caracteriza pela sua resistência e absorção.

EN Reel of certified 100% virgin cellulose tissue characterized by its strength and absorption.



Resistencia · Résistance
Resistência · Resistance

Absorción
Absorption · Absorção



J000048

► Gofrado de bordes / Gaufrage des bords / Gofragem das extremidades / Edges embossing

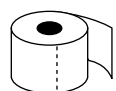

Secamanos
Maxi Mains
Seca-Mãos
Hand Towel



		n°	Ø mm	Ø mm	n°	m	mm	Units x bag	Bags x Pallet
J288205	GC 150 ST	2	190	76	450	150	200	6	44

► Gofrado ADD System / Gaufrage ADD System / Gofragem ADD System / ADD System embossing

		n°	Ø mm	Ø mm	n°	m	mm	Units x bag	Bags x Pallet
J289301	GC COMPACT 60 ST	2	130	45	255	60	230	2x6	50
J288123	GC 60 MINI ST	2	130	45	255	60	200	6	88
J000048*	GC 138 MULTIUSO	2	200	45	600	138	224	1x6	40
J288600	GC 143 ST	2	200	76	477	143	200	6	44
NEW! J288867	GC 140 LT	2	185	76	466	140	184	6	52
NEW! J288894	GC 120 LT	2	185	76	400	120	184	6	52

ST = Standard
LT = Light

*Secamanos unitario /Maxi mains unitaire
Seca-mãos unitário / Unitary hand towel roll



Gofrado de bordes.
Gaufrage des bords.
Gofragem das extremidades.
Edges embossing.



Dispensador / Distributeur / Dispensador / Dispenser

NEW!

100% Recycled

Dispensador Secamanos
Distributeur Maxi mains
Dispensador Seca-mãos
Hand towel dispenser

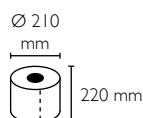

Dispenser Size

J288011 100% Recycled Plastic 200X310X220

1 Unit x Box

Diseño polivalente que se adapta a cualquier espacio. Ideal para aseos y cocinas con un tránsito elevado. Fabricado con plástico ABS 100% reciclado.

Design polyvalent qui s'adapte à tous les espaces. Idéal pour les toilettes et les cuisines à forte fréquentation. Fabriqué avec du plastique ABS 100% recyclé.

Design polivalente que se adapta a qualquer espaço. Ideal para casas de banho e cozinhas com elevada afluência. Fabricado com plástico ABS 100% reciclado.

Multipurpose design suitable for all spaces. Ideal for toilets and kitchens with high influx of people. Made with 100% recycled ABS plastic.

AUTO-CORTE · AUTOCUT · AUTOCORTE · SELF-CUTTING · AUTO-CORTE · AUTOCUT

ES Bobinas sin precorte, indicadas para el secado higiénico de las manos.

FR Bobine sans prédécoupage, destinée au séchage hygiénique des mains.

PT Bobinas sem pré-corte, indicadas para a secagem higiénica das mãos.

EN Reels without pre-cut tissue suitable for hygienic hand drying.



► Gofrado ADD System / Gaufrage ADD System / Gofragem ADD System / ADD System embossing

Secamanos Maxi Mains Seca-Mãos Hand Towel									
		n°	Ø mm	Ø mm	n°	m	mm	Units x bag	Bags x Pallet
J288115	GC ecologic+ 150 XXT	1	160	45	536*	150	200	6	55
J288110	GC ecologic+ 240 XXT	1	200	45	857*	240	200	6	44
J288420	GC ecologic+ 100 XT	2	160	45	357*	100	200	6	55
J288440	GC ecologic+ 120 XT	2	180	45	429*	120	200	6	44
J288247	GC TECH Blue 150 ST	2	195	45	536*	150	200	6	44
J288221	GC ecologic+ 150 XT	2	200	45	536*	150	200	6	44
J288225	GC 150 ST	2	200	45	536*	150	200	6	44

XT = Extra / XXT = Extra Plus

*Servicios aproximados dependiendo del modelo de dispensador auto-corte. / * Formats approximatifs en fonction du modèle de distributeur à découpe automatique. / * Número de serviços aproximado conforme o modelo de dispensador autocorte utilizado. / * Approximate number of services depending on the model of autocut dispenser.

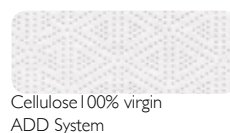

J288507

100% FIBRAS RECICLADAS · 100% FIBRES RECYCLÉES · 100% FIBRAS RECICLADAS · 100% RECYCLED FIBERS

ES La combinación de alto gramaje con acabado ADD system en la bobina de tejido GC TECH proporciona resistencia y absorción para la limpieza de entornos profesionales

FR La combinaison d'un grammage élevé avec la finition ADD System dans la bobine de tissu GC TECH offre résistance et absorption pour le nettoyage des environnements professionnels.

PT A combinação de alta gramagem com acabamento em ADD system na bobina de tecido GC TECH oferece resistência e absorção para a limpeza de ambientes profissionais

EN The combination of high weight with ADD system finish in the GC TECH tissue roll provides strength and absorption for cleaning in professional environments.



The mark of responsible forestry



J288399



Resistencia · Résistance
Resistência · Resistance

Absorción
Absorption · Absorção



J288856



► Gofrado ADD System / Gaufrage ADD System / Gofragem ADD System / ADD System embossing

	Secamanos Maxi Mains Seca-Mãos Hand Towel roll								
		n°	Ø mm	Ø mm	n°	m	mm	Units x bag	Bags x Pallet
J288856	GC TECH Blue 106 ST	2	190	76	450	106	200	6	44
J288292	GC TECH Blue 143 ST	2	200	76	450	143	200	6	44
J288399	GC TECH Tissue 106 XT	2	190	76	450	106	200	6	44

ST = Standard XT = Extra



AIRLAID · MATERIAL TÉCNICO · AIRLAID · MATÉRIEL TECHNIQUE · AIRLAID · TECHNICAL MATERIAL · AIRLAID

ES La bobina de Airlaid GC TECH ofrece máxima resistencia y absorción para la limpieza de entornos profesionales exigentes sin desprender pelusa.

FR La bobine d'Airlaid GC TECH offre une résistance et une absorption maximales pour le nettoyage des environnements professionnels exigeants en empêchant la formation de peluches.

PT A bobina do Airlaid GC TECH oferece resistência e absorção máximas para a limpeza de ambientes profissionais exigentes sem libertar fapos.

EN The Airlaid GC TECH roll, offers maximum resistance and absorption for cleaning in professional environments with minimum fibre loss.



Food Contact



Sin pelusa · Ne peluche pas
Lint-free



Extra Resistencia · Résistance
Resistência · Resistance



Extra Absorción
Absorption · Absorção



Airlaid



► Gofrado Airlaid / Gaufrage Airlaid / Gofragem Airlaid / Airlaid embossing

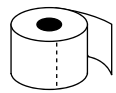

Secamanos
Maxi Mains
Seca-Mãos
Hand Towel

		n°	Ø mm	Ø mm	n°	m	mm	Units x bag	Bags x Pallet
J288165	GC TECH Airlaid 54 XT	1	190	76	200	54	200	3	96

XT= Extra

BENEFICIOS AIRLAID / AVANTAGES DE L'AIRLAID / BENEFÍCIOS AIRLAID / AIRLAID BENEFITS

- Reducción de los costes y ahorro de tiempo.
- Mayor rendimiento, rapidez y eficacia.
- Resultados óptimos.
- Mayor calidad para el usuario.
- Mayor higiene y seguridad.
- Adecuado para: industria profesional de limpieza y mantenimiento, sector salud, sector restauración e industria alimentaria.
- Réduction des coûts et gain de temps.
- Performances, vitesse et efficacité accrues.
- Des résultats optimaux.
- Qualité supérieure pour l'utilisateur.
- Plus d'hygiène et de sécurité.
- Convient pour: l'industrie professionnelle du nettoyage et de l'entretien, le secteur de la santé, la restauration et l'industrie alimentaire.
- Redução de custos e economia de tempo.
- Maior desempenho, velocidade e eficiência.
- Óptimos resultados.
- Maior qualidade para o usuário.
- Maior higiene e segurança.
- Adequado para: indústria profissional de limpeza e manutenção, sector de saúde, restauração e indústria alimentar.
- Cost reduction and time saving .
- Greater performance, speed and efficiency.
- Optimal results.
- Higher quality for the user.
- Greater hygiene and safety.
- Suitable for: professional cleaning and maintenance industry, health sector, catering and food industry.

100% FIBRAS RECICLADAS · 100% FIBRES RECYCLÉES · 100% FIBRAS RECICLADAS · 100% RECYCLED FIBERS

ES Bobina de celulosa reciclada y certificada de gran tamaño para la limpieza en entornos de trabajo profesional de uso intensivo.

FR Grande bobine de ouate recyclée et certifiée pour le nettoyage des milieux professionnels à usage intensif.

PT Bobina de celulose reciclada e certificada de grande tamanho para limpeza em ambientes de trabalho profissional de uso intensivo.

EN Reel of recycled, certified cellulose in a large size ideal for intensive use to clean professional work environments.



The mark of responsible forestry



Resistencia · Résistance
Resistência · Resistance



Absorción · Absorption
Absorção · Absorção



J286102



J286060



Gofrado liso
Gaufrage lisse
Gofragem lisa
Plain embossed



Gofrado de bordes.
Gaufrage des bords.
Gofragem das extremidades.
Edges embossing.



► Gofrado liso / Gaufrage lisse / Gofragem lisa / Plain embossing

Celulosa industrial Bobine industrielle Celulose industrial Industrial Cellulose										
		n°	Mandril	Ø mm	Ø mm	n°	m	mm	Units x bag	Bags x Pallet
J286010	GC ecologic+ 1000	1	-	350	76	2.857	1.000	230	2	40

► Gofrado de bordes / Gaufrage des bords / Gofragem das extremidades / Edges embossing

		n°	Mandril	Ø mm	Ø mm	n°	m	mm	Units x bag	Bags x Pallet
J286045	GC ecologic+ 500 ST	2	-	341	76	1.500	500	230	2	40
J286028	GC ecologic+ 600 ST	2	-	362	76	1.714	600	230	2	30
J286022	GC ecologic+ 800 ST	2	-	415	76	2.285	800	230	2	30

► Gofrado ADD System / Gaufrage ADD System / Gofragem ADD System / ADD System embossing

		n°	Mandril	Ø mm	Ø mm	n°	m	mm	Units x bag	Bags x Pallet
J881000	GC ecologic+ 240 ST	2	✓	265	76	800	240	230	2	60
J286117	GC ecologic+ 300 ST	2	✓	280	76	1.000	300	230	2	60
J286102*	GC ecologic+ 300 ST	2	✓	280	76	1.000	300	230	1x2	2x24
J286060	GC ecologic+ 400 ST	2	✓	331	76	1.212	400	230	2	40

*Secamanos unitario / Maxi mains unitaire / Seca-mãos unitário / Unitary hand towel roll

ST = Standard

100% FIBRAS RECICLADAS · 100% FIBRES RECYCLÉES · 100% FIBRAS RECICLADAS · 100% RECYCLED FIBERS

ES Celulosa industrial de color havana certificada compuesta por fibras de celulosa reciclada presentes en los envases de cartón.

FR Bobine industrielle de couleur havane certifié, composée de fibres de ouate de cellulose recyclée présentes dans les emballages carton.

PT Celulose industrial na cor havana, certificada composta por fibras de celulosa reciclada presentes nas embalagens de cartão.

EN Industrial cellulose of Nature color; made of recycled cellulose from cardboard packaging.



The mark of responsible forestry



Resistencia · Résistance
Resistência · Resistance



Absorción
Absorption · Absorção

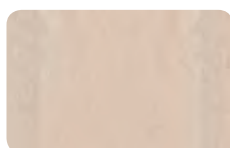

J286905

► Gofrado de bordes / Gaufrage des bords / Gofragem das extremidades / Edges embossing

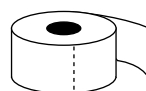

Celulosa industrial
Bobine industrielle
Celulose industrial
Industrial Cellulose



n°



Mandril



Ø mm



Ø mm



n°



m



mm



Units x bag



Bags x Pallet

J286900

GC Nature 300 ST

2

✓

270

76

1.000

300

230

2

60

ST = Standard

ST = Standard



J286500

100% CELULOSA VIRGEN · 100% PURE PÂTE · 100% CELULOSE VIRGEM · 100% VIRGIN CELLULOSE

ES Bobina de papel tisú certificada de gran tamaño para la limpieza en entornos de trabajo profesionales de uso intensivo.

FR Grande bobine de papier tissu certifié pour le nettoyage des milieux professionnels à usage intensif.

PT Bobina de papel tissue certificada de grande tamanho destinada à limpeza de ambientes de trabalho profissionais de uso intenso.

EN Reel of certified tissue paper in a large size ideal for intensive use to clean professional work environments.



Resistencia · Résistance
Resistência · Resistance



Absorción
Absorption · Absorção



J286103

► Gofrado de bordes / Gaufrage des bords / Gofragem das extremidades / Edges embossing

Celulosa industrial Bobine industrielle Celulose industrial Industrial Cellulose										
		n°	Mandril	Ø mm	Ø mm	n°	m	mm	Units x bag	Bags x Pallet
J286104	GC 300 ST	2	✓	270	76	1.000	300	230	2	60
J286046	GC 500 ST	2	✓	320	76	1.500	500	230	2	40

► Gofrado ADD System / Gaufrage ADD System / Gofragem ADD System / ADD System embossing

		n°		Ø mm	Ø mm	n°	m	mm	Units x bag	Bags x Pallet
J286103	GC 450 ST	2	✓	330	76	1.500	450	230	2	40

ST = Standard



Gofrado de bordes.
Gaufrage des bords.
Gofragem das extremidades.
Embossed edges.



NEW !



Dispensador de Celulosa Industrial
Distributeur Bobine industrielle
Dispensador de Celulose Industrial
Industrial cellulose Dispenser

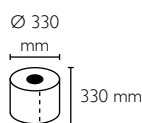

J288533 Plastic

Dispenser Size

400x330x330

1 U. x Box

Dispensador cerrado de pared, 100% higiénico, cerrado para evitar la contaminación. Compatible con rollos de menos de 330 mm diámetro.

Distributeur mural fermé, 100% hygiénique, fermé pour éviter toute contamination. Compatible avec les rouleaux de moins de 330 mm de diamètre.

Dispensador de parede fechado, 100% higiénico, fechado para evitar contaminação. Compatível com rolos de diâmetro inferior a 330 mm.

Closed wall dispenser, 100% hygienic, closed to avoid contamination. Compatible with rolls of less than 330 mm diameter.

100% FIBRAS RECICLADAS · 100% FIBRES RECYCLÉES · 100% FIBRAS RECICLADAS · 100% RECYCLED FIBERS

ES La combinación de alto gramaje con acabado ADD system en la bobina de tejido GC TECH proporciona resistencia y absorción para la limpieza de entornos profesionales. La utilización del color azul minimiza el riesgo de contaminación cruzada.

FR La combinaison du grammage élevé et la finition ADD System sur la bobine en tissu GC TECH offre résistance et absorption pour le nettoyage des milieux professionnels. L'utilisation de la couleur bleue minimise le risque de contamination croisée.

PT A combinação de alta gramagem com acabamento ADD System na bobina de tecido GC TECH proporciona resistência e absorção para a limpeza de ambientes profissionais. O uso da cor azul minimiza o risco de contaminação cruzada.

EN The combination of high grammage and the ADD System Finish used in our GC TECH reel of tissue paper offers strength and absorption for cleaning in professional environments. The use of blue color minimizes the risk of cross contamination.



The mark of responsible forestry



Resistencia · Résistance
Resistência · Resistance



Absorción
Absorption · Absorção



► Gofrado ADD System / Gaufrage ADD System / Gofragem ADD System / ADD System embossing

Icon	Celulosa industrial Bobine industrielle Célulose industrial Industrial Cellulose	Gofrado / Gaufrage / Gofragem / ADD System embossing				Roll Dimensions			Packaging	
		n°	Ø mm	Ø mm	n°	m	mm	Units x bag	Bags x Pallet	
	J286343 GC TECH Blue 285 ST	3	-	341	76	750	285	230	2	40
	J286041 GC TECH Blue 400 ST	2	✓	330	76	1.212	400	230	2	40
	J286007 GC TECH Tissue 570 XT	2	-	385	76	1.628	570	230	2	30

ST = Standard XT= Extra



AIRLAID · MATERIAL TÉCNICO · AIRLAID · MATÉRIEL TECHNIQUE · AIRLAID · TECHNICAL MATERIAL · AIRLAID

ES La bobina de Airlaid GC TECH ofrece máxima resistencia y absorción para la limpieza de entornos profesionales exigentes sin desprender pelusa.

FR La bobine d'Airlaid GC TECH offre une résistance et une absorption maximales pour le nettoyage des environnements professionnels exigeants sans libérer de peluches.

PT A bobina do Airlaid GC TECH oferece resistência e absorção máximas para a limpeza de ambientes profissionais exigentes sem libertar fiapos.

EN The GC Tech Airlaid reel offers maximum resistance and absorption for the cleaning of demanding professional environments without releasing lint.

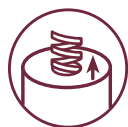

J284000



Airlaid

► Gofrado Airlaid / Gaufrage Airlaid / Gofragem Airlaid / Airlaid embossing

	Celulosa industrial Bobine industrielle Celulose industrial Industrial Cellulose	n°		Ø mm	Ø mm	n°	m	mm	Units x bag	Bags x Pallet
J284000	GCTECH Airlaid 130 XT	1	✓	300	76	371	130	230	2	60

XT= Extra



PAPEL DE COCINA / ESSUIE-TOUT MÉNAGER PAPEL DE COZINHA / KITCHEN ROLL



100% CELULOSA VIRGEN · 100% PURE PÂTE · 100% CELLULOSE VIRGEM · 100% VIRGIN CELLULOSE

ES Rollos de cocina de celulosa virgen de excelente calidad, absorción y resistencia gracias a su exclusivo gofrado de círculos absorbentes. Infalibles contra la suciedad de las cocinas más exigentes.

FR Rouleau essuie-tout ménager en ouate vierge d'une qualité, absorption et résistance excellentes, grâce à son gaufrage exclusif de cercles absorbants. Infaillible contre la saleté des cuisines les plus exigeantes.

PT Rolos de cozinha de celulosa virgem de excelente qualidade, absorção e resistência graças à sua exclusiva gofragem de círculos absorventes. Infalíveis contra a sujidade nas cozinhas mais exigentes.

EN Kitchen roll made from excellent-quality virgin cellulose offering high strength and absorption achieved through an exclusive embossed circle design. Unbeatable against dirt in exigent kitchens.



The mark of responsible forestry



Resistencia · Résistance
Resistência · Resistance



Absorción
Absorption · Absorção



C000177



C000178



Papel de cocina
Essuie-tout ménager
Papel de cozinha
Kitchen roll

		n°	n°	m	Rolls x Pack	Units x bag	Bags x Pallet
C000178	GC 48	2	48	10,8	2	48 (24 packs)	20
C000177	GC MAXI 90	2	90	21,6	4	24	30

Kitchen / Cocina Cuisine / Cozinha



TOALLAS DE MANO / ESSUIE-MAINS ENCHEVETRES TOALHAS DE MÃO / HAND TOWELS



100% FIBRAS RECICLADAS · 100% FIBRES RECYCLÉES · 100% FIBRAS RECICLADAS · 100% RECYCLED FIBERS

ES Ecológicas y certificadas las toallas de mano GC ecologic+ son absorbentes gracias al exclusivo sistema Xtrasec de unión de capas que aporta una suavidad, comodidad y resistencia inmejorable.

FR Écologiques et certifiés les essuie-mains enchevêtrés GC ecologic+ sont absorbants grâce au système exclusif de collage des plis Xtrasec qui offre une douceur, une résistance et un confort inégalés.

PT Ecológicas e certificadas as toalhas de mão GC ecologic+ são absorventes graças ao exclusivo sistema Xtrasec de união de camadas que confere uma maciez, conforto e resistência excelentes.

EN Ecological and certified GC ecologic+ hand towels are absorbent thanks to their exclusive Xtrasec ply bonding system that gives this paper unbeatable softness, comfort and strength.



The mark of responsible forestry



J281600



Suave
Doux - Soft



Resistencia - Résistance
Resistência - Resistance

XTRASEC
atracción por el agua



Toallas de Mano
Essuie-Mainss Enchevêtrés
Toalhas de Mão
Hand Towels

		n°	mm	mm	Units x Pack	Units x Box	Box x Pallet
J281600	GC ecologic+ Folded V	2	200 x 230	100	196	3.920	36
J283500	GC ecologic+ Folded V	2	200 x 230	100	4 x 196	3.920	36
J281400	GC ecologic+ Folded Z	2	235 x 230	80	192	3.840	36
J281900	GC ecologic+ Folded W	2	310 x 225	80	144	2.880	36



XTRASEC
atracción por el agua



ES Sistema exclusivo de unión de capas de papel que confiere un extra de suavidad, comodidad y resistencia para las toallas de mano.

FR Le système exclusif de collage des plis de papier offre plus de douceur, de confort et de résistance aux essuie-mains enchevêtrés.

PT Sistema exclusivo de união de camadas de papel que confere uma maciez extra, conforto e resistência para as toalhas de mão.

EN An exclusive ply bonding system offering extra softness, comfort and strength to hand towels.

TOALLAS DE MANO NATURE / ESSUIE-MAINS ENCHEVETRES NATURE TOALHAS DE MÃO NATURE / HAND TOWELS



100% FIBRAS RECICLADAS · 100% FIBRES RECYCLÉES · 100% FIBRAS RECICLADAS · 100% RECYCLED FIBERS

ES Nuestras toallas de mano certificadas Nature están compuestas por fibras de celulosa reciclada presentes en los envases de cartón.

FR Nos essuie-mains enchevêtrés Nature sont composés de fibres de ouate recyclée présentes dans les emballages carton.

PT As nossas toalhas de mão certificadas Nature são compostas por fibras de celulosa reciclada presentes nas embalagens de cartão.

EN Our certified Nature hand towels are made of recycled cellulose fibers from cardboard packaging.



XTRASEC
atracción por el agua



Toallas de Mano
Essuie-Mains Enchevêtrés
Toalhas de Mão
Hand Towels

		n°	mm	mm	Units x Pack	Units x Box	Box x Pallet
J282100	GC Nature Folded V	2	200 x 230	100	196	3.920	36

TIPOS DE PLEGADOS / TYPES DE PLIAGES / TIPOS DOBRADO / TYPES FOLDED



El plegado V ofrece una higiene óptima y una fácil dispensación.

Le pliage V offre une hygiène optimale et une distribution facile.

A dobra em V oferece uma higiene óptima e uma fácil dispensação.

The V fold offers optimal hygiene and easy dispensing.



El plegado Z ofrece una gran capacidad de secado y un panel más estrecho que las toallas en V.

Le pliage Z offre une plus grande capacité de séchage et un dos plus étroit que les essuie-mains en V.

A dobra em Z oferece uma grande capacidade de secagem e um painel mais estreito que as toalhas em V.

The Z fold offers a generous drying capacity and narrower panel than the V fold towels.



La toalla W es más larga y con una capacidad de secado máxima.

L'essuie-mains en W est plus long et sa capacité de séchage est supérieure.

A toalha em W é mais larga e com uma capacidade de secagem máxima.

The W fold towel is longer and offers a maximum drying capacity.

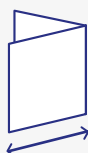

Panel: Es la medida de la toalla plegada, a tener en cuenta para la colocación de las toallas en los dispensadores.

Dos : C'est la mesure de l'essuie-mains enchevêtré, dont il faut tenir compte pour placer les essuie-mains dans les distributeurs.

Painel: É a medida da toalha dobrada a considerar para a colocação das toalhas nos dispensadores.

Panel: This is the dimension of the towel when folded, which must be taken into account to ensure that they fit correctly in dispensers.

100% CELULOSA VIRGEN · 100% PURE PÂTE · 100% CELULOSE VIRGEM · 100% VIRGIN CELLULOSE

ES Las toallas de mano 100% pura celulosa son extra absorbentes gracias al exclusivo sistema Xtrasec de unión de sus 2 capas que dan al papel un extra en suavidad y resistencia, así como comodidad.

FR Les essuie-mains enchevêtrés 100% pure ouate sont extra absorbants grâce au système exclusif Xtrasec de collage de ses deux plis qui confèrent au papier une douceur et une résistance supplémentaires, ainsi que du confort.

PT As toalhas de mão 100% pura celulosa são extra-absorventes graças ao exclusivo sistema Xtrasec de união das suas 2 camadas que conferem ao papel um plus em maciez, resistência e conforto.

EN These 100% pure cellulose hand towels are extra absorbent thanks to the exclusive Xtrasec system used to join the two plies that give this paper extra softness, comfort and strength.



The mark of responsible forestry



Suave
Doux · Soft



Resistencia · Résistance
Resistência · Resistance



J281700

XTRASEC
atracción por el agua



Toallas de Mano
Essuie-Mains Enchevêtrés
Toalhas de Mão
Hand Towels

		n°	mm	mm	Units x Pack	Units x Box	Box x Pallet
J281700	GC Folded V	2	200 x 230	100	196	3.920	36
J281500	GC Folded Z	2	235 x 230	80	192	3.840	36
J282000	GC Folded W	2	310 x 225	80	144	2.880	36

Dispensador / Distributeur / Dispensador / Dispenser

NEW!

100% Recycled



Dispensador toallas de mano
Distributeur essuie-mains enchevêtrés
Dispensador toalhas de mão
Hand towels dispenser



24 cm

J288013	100% Recycled Plastic, white	Dispenser Size 271x360x131
8 U. x Box		

Dispensador compacto ideal para aseos con tránsito elevado e intenso. Fabricado con plástico ABS 100% reciclado.
 Distributeur compact, idéal pour les toilettes à forte fréquentation. Fabriqué avec du plastique ABS 100% recyclé.
 Dispensador compacto ideal para casas de banho com elevada afluência. Fabricado com plástico ABS 100% reciclado.
 Compact dispenser ideal for toilets with high and intense influx of people. Made with 100% recycled ABS plastic.

TOALLAS DE MANO / ESSUIE-MAINS ENCHEVETRES TOALHAS DEMÃO / HAND TOWELS



100% FIBRAS RECICLADAS · 100% FIBRES RECYCLÉES · 100% FIBRAS RECICLADAS · 100% RECYCLED FIBERS

ES Toalla celulosa azul indicada para cocinas profesionales y el sector alimentario. La utilización del color azul minimiza el riesgo de contaminación cruzada.

FR L'essuie-mains enchevêtré en cellulose bleue est indiqué pour les cuisines professionnelles et le secteur alimentaire. L'utilisation de la couleur bleue minimise le risque de contamination croisée.

PT A toalha de celulose azul indicada para cozinhas profissionais e sector alimenta. O uso da cor azul minimiza o risco de contaminação cruzada.

EN Blue cellulose towel aimed for professional kitchens and the food sector. The use of blue color minimizes the risk of cross contamination.



Toallas de Mano
Essuie-Mains Enchevêtrés
Toalhas de Mão
Hand Towels

J281800

GCTECH Blue Folded V



n°

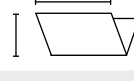

mm
200 x 230



mm
100



Units x Pack
196

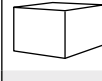

Units x Box
3.920

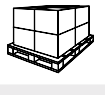

Box x Pallet
36

AIRLAID · MATERIAL TÉCNICO · AIRLAID · MATÉRIEL TECHNIQUE · AIRLAID · TECHNICAL MATERIAL · AIRLAID

ES Alta resistencia y absorción para las toallas de mano Airlaid. Son perfectas para aquellos hoteles y restaurantes que quieran diferenciarse con un producto similar a la tela.

FR Haute résistance et absorption pour les essuie-mains Airlaid. Ils sont parfaits pour les hôtels et restaurants qui veulent se différencier avec un produit similaire au tissu.

PT Alta resistência e absorção para as toalhas de mão Airlaid. São perfeitas para hotéis e restaurantes que desejem diferenciar-se com um produto semelhante ao tecido.

EN High resistance and absorption for Airlaid hand towels. They are perfect for those hotels and restaurants that want to differentiate themselves with a product similar to fabric.



Airlaid

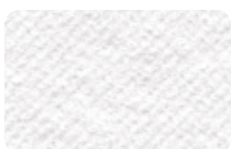

Toallas de Mano
Essuie-Mains Enchevêtrés
Toalhas de Mão
Hand Towels

T261121

GCTECH Airlaid Folded 1/6 ST

ST = Standard



n°
1

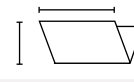

mm
300 x 400



mm
100



Units x Pak
70

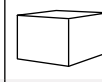

Units x Box
840



Box x Pallet
49



**ROLLO PAPEL CAMILLA, PAÑUELOS, FACIALES,
TOALLAS DESECHABLES**

Higiene y cuidado de la salud.

**DRAPS D'EXAMEN, BOITES ET PAQUETS DE
MOUCHOIRS, SERVIETTES JETABLES**

Hygiène et soins de santé.

**ROLO PAPEL PARA MACA, LENÇOS,
LENÇOS FACIAIS E TOALHAS DESCARTÁVEIS**

Higiene e cuidados de saúde.



**MEDICAL ROLLS, PAPER HANDKERCHIEFS,
FACE TISSUES AND DISPOSABLE TOWELS**

Hygiene and health care.

ROLLO CAMILLA / DRAPS D'EXAMENS ROLO PAPEL PARA MACA / MEDICAL ROLL

100% FIBRAS RECICLADAS · 100% FIBRES RECYCLÉES · 100% FIBRAS RECICLADAS · 100% RECYCLED FIBERS

ES Rollos para uso sanitario absorbentes y resistentes de 46 a 80 m de longitud: una superficie higiénica para camillas y camas de hospital. En todas las anchuras habituales: 50 y 59 cm.

FR Draps d'examens pour usage sanitaire absorbants et résistants de 46 à 80 m de long : une surface hygiénique pour les tables d'auscultations et les lits d'hôpital. Pour toutes les largeurs habituelles : 50 et 59 cm.

PT Rolos para uso sanitario absorbentes e resistentes de 46 a 80 m de comprimento: uma superfície higiénica para macas e camas de hospital. Em todas as larguras habituais: 50 e 59 cm.

EN Strong and absorbent paper rolls for sanitary use from 46 to 80 m. Provides a hygienic surface for stretchers and hospital beds. Available in all standard widths: 50 and 59 cm.



The mark of responsible forestry



Resistencia · Résistance
Resistência · Resistance



J289120

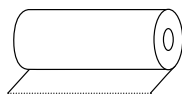
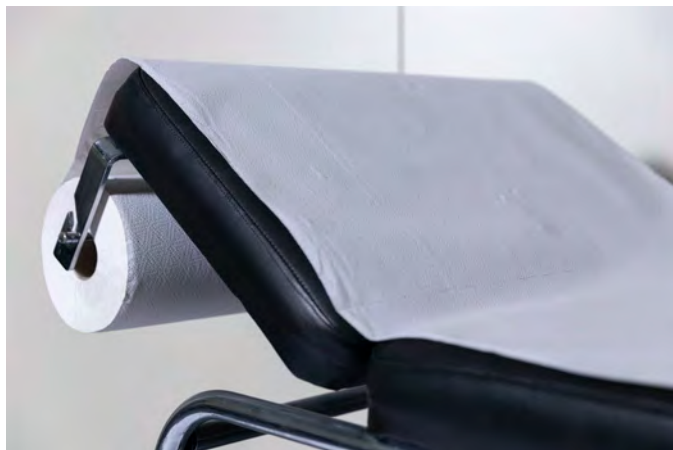

Rollo camilla
Draps d'examens
Marquesa
Medical roll



	n°	ø mm	n°	m	mm	Units x bag	Box x Pallet
J289030* GC ecologic+ 46 (Precut 40 cm)	2	45	125	46	500	6	36
J289144* GC ecologic+ 80 (Precut 40 cm)	2	45	200	80	590	6	24
J289120* GC ecologic+ 80 (Precut 200 cm)	2	45	40	80	590	6	24

*Embalaje unitario del rollo. / Emballage unitaire du rouleau. / Embalagem unitária do rolo. / Unitary roll packing.

Dispensador / Distributeur / Dispensador / Dispenser



Dispensador rollo camilla
Distributeur draps d'examens
Dispensadores rolo marquesa
Medical Roll dispenser



Dispenser Size

J289500 Metallic / Plastic
1 U. x Box

620x210

Resistente, compacto y de fácil instalación en camillas.
Résistant, compact et facile à installer sur les lits.
Resistente, compacto e de fácil instalação em macas.
Resistant, compact and easy to install on beds.

100% CELULOSA VIRGEN · 100% PURE PÂTE · 100% CELOULOSE VIRGEM · 100% VIRGIN CELLULOSE

ES Pañuelos de bolsillo (pocket) de papel tisú de gran calidad y absorción. Con un diseño renovado. Tenlos siempre a mano.

FR Mouchoirs en papier de haute qualité et absorbants. Avec un design renouvelé. Gardez-les toujours à portée de main.

PT Lenços de bolso de papel tissue de alta qualidade e absorção. Com um design renovado. Mantenha-os sempre à mão.

EN Pocket tissues of high quality and very absorbing. With a renewed design. Keep them always at hand.



The mark of responsible forestry



Suave
Doux · Soft



Resistencia · Résistance
Resistència · Resistance



B280080
10x10 U. Grouping

	Pañuelos Mouchoirs Lenços Handkerchiefs				
		n°	Units x Pack	Pack x Box	Box x Pallet
B280080	GC Paper Handkerchiefs	3	10x10 U. Grouping	25 Grouping x Box	80

FACIALES / MOUCHOIRS
LENÇOS FACIAIS / FACE TISSUES



100% FIBRAS RECICLADAS · 100% FIBRES RECYCLÉES · 100% FIBRAS RECICLADAS · 100% RECYCLED FIBERS

ES Pañuelos faciales GC Ecologic+ de tisú 100% reciclado de excelente calidad muy agradables para la piel. Se pueden extraer por la parte delantera y trasera de la caja. Con packaging 0% plástico.

FR Mouchoirs en tissu GC Ecologic+ 100% recyclés d'une excellente qualité très agréable à la peau. Ils peuvent être retirés au dessus et en dessous de la boîte. Avec un packaging avec 0% de plastique.

PT Lenços faciais GC Ecologic+ tissue 100% reciclado de excelente qualidade, muito agradável para a pele. Podem ser retirados tanto pela parte dianteira como traseira da caixa. Com 0% de embalagem plástica.

EN GC Ecologic+ facial tissues made of 100% recycled tissue are of excellent quality and pleasant to the skin. They can be pulled out from the front and back of the box. 0% plastic packaging.



The mark of responsible forestry



Suave
Doux · Soft

	Pañuelos faciales Boîtes et paquets de mouchoirs Lenços faciais Face Tissues				
		n°	Units x Pack	Pack x Box	Box x Pallet
F283308	GC ecologic+	2	100	80	20



100% CELULOSA VIRGEN · 100% PURE PÂTE · 100% CELOULOSE VIRGEM · 100% VIRGIN CELLULOSE

ES Pañuelos faciales de papel tisú de excelente calidad muy agradables para la piel. Con un diseño renovado y libre de plástico, manteniendo la calidad de siempre. También en formato de cubo, con colores suaves y elegantes.

FR Mouchoirs en papier mousseline d'excellente qualité très agréable à la peau. Avec un design renouvelé et sans plastique, conservant toujours la même qualité. Egalement en format cube, avec des couleurs douces et élégantes.

PT Lenços de papel tissue de excelente qualidade e muito agradáveis para a pele. Com um design renovado e sem plástico, mantendo a mesma qualidade de sempre. Também em formato de cubo, com cores suaves e elegantes.

EN Facial tissues of excellent quality, very nice to the skin. With a renewed and plastic-free design, maintaining the same quality as always. Also in cube format, with soft and elegant colors.



The mark of responsible forestry



Suave
Doux · Soft

Pañuelos faciales
Boîtes et paquets de mouchoirs
Lenços faciais
Face Tissues



F283001 / F283101

F283205

		n°	Units x Pack	Pack x Box	Box x Pallet
F283001	GC Face Tissues	2	100	24	60
F283101	GC Face Tissues	2	100	80	20
F283205	GC Face Tissues Cube	2	80	30	36



NUEVAS MASCARILLAS
NOVAS MÁSCARAS
NOUVEAUX MASQUES
NEW MASKS



- Fabricación española
 - Gama completa para todas las necesidades
 - Tecnología Nanofibras + filtro viricida (sin Grafeno).
 - Filtración mecánica. Mantiene las propiedades filtrantes a lo largo del tiempo.
 - Más ligeras y cómodas gracias a las Nanofibras
- Fabricado em Espanha
 - Gama completa para todas as necessidades
 - Tecnologia de Nanofibras + filtro viricida (sem Grafeno).
 - Filtração mecânica. Mantém as propriedades filtrantes ao longo do tempo.
 - Mais ligeiras e cómodas, graças às Nanofibras
- Fabrication européenne
 - Gamme complète pour tous les besoins
 - Technologie nanofibre + filtre virucide (sans graphène).
 - Filtration mécanique qui permet de garder les propriétés de filtrage dans le temps.
 - Plus légères grâce aux nanofibres.
- Spanish manufacture
 - Full range for all the families
 - Nanofiber Technology + filter virucidal (without graphene).
 - Mechanical filtration. keep the filtering properties throughout of time.
 - Lighter due to nanofibers



W00015



W00016

Ref.	W00015	W00016
Talla / Tamanho / Taille / Size	L/M	M/S
Tipo / Type	FFP2	FFP2
Norma / Norm / Norme	UNE-EN 149:2021+A1:2009	UNE-EN 149:2021+A1:2009
Filtración / Filtração / Filtration	94%	94%
Desinfectable/ Desinfectável / Désin	SI	SI
Unidades caja / Unidades Caixa / Unité caisse / Units box	15	15
Hook	18	18

Consulta con tu delegado/a comercial nuestra gama de mascarillas.
 Consulte o seu gestor comercial sobre a nossa gama de máscaras.
 Vérifiez auprès de votre délégué commercial notre gamme de masques.
 Check with your delegate comercial our range of masks.



PAÑOS NO TEJIDOS

Los paños no tejidos son una combinación de fibras naturales y sintéticas, fabricadas con diversas técnicas industriales avanzadas y la modificación de su estructura para crear paños individuales con propiedades de limpieza específicas.

CHIFFONS NON-TISSÉS

Les chiffons non-tissés combinent des fibres naturelles et synthétiques, fabriquées moyennant diverses techniques industrielles avancées. La modification de leur structure permet la création de chiffons individuels ayant des propriétés nettoyantes spécifiques.

PANOS NÃO TECIDOS

Os panos não tecidos são uma combinação de fibras naturais e sintéticas, fabricadas com diversas técnicas industriais avançadas, cuja alteração na sua estrutura permite criar panos individuais com propriedades de limpeza específicas.

NON-WOVEN WIPES

Non-woven cloths made from a combination of natural and synthetic fibers and manufactured using various advanced industrial techniques to modify their structure and create individual wipes with specific cleaning properties.

CHICOPEE[®]



J Cloth compostable

El paño J-Cloth Plus está realizado con una textura única, abierta y ondulada que permite la recogida eficiente de cualquier partícula de suciedad. Fácil de enjuagar y se seca rápidamente. El paño permanece limpio e higiénico por mucho tiempo y se puede desechar después de su uso.

J Cloth compostable

Le chiffon compostable J-Cloth est fait de fibres naturelles certifiées. De plus, l'emballage est également compostable. Sa structure ouverte permet une collecte efficace de toutes les particules de saleté. Facile à rincer et sèche rapidement.

J Cloth compostable

O pano compostável J-Cloth é feito de fibras naturais certificadas. Além disso, a bolsa também é compostável. A sua estrutura aberta permite a recolha eficiente de qualquer partícula de sujidade. Fácil de enxaguar e secagem rápida.

J Cloth compostable

The J-Cloth compostable cloth is made of certified natural fibers. In addition the bag is also compostable. Its open structure allows efficient collection of any dirt particles. Easy to rinse and dries quickly.



	Color	Size cm	Pack x Box	Box x Pallet
0074441	Yellow	43x32	50 x 10	50
0074442	Red	43x32	50 x 10	50
0074443	Blue	43x32	50 x 10	50
0074444	Green	43x32	50 x 10	50

J-Cloth Plus

El paño J-Cloth Plus está realizado con una textura única, abierta y ondulada que permite la recogida eficiente de cualquier partícula de suciedad. Fácil de enjuagar y se seca rápidamente. El paño permanece limpio e higiénico por mucho tiempo y se puede desechar después de su uso.

J-Cloth Plus

Le chiffon J-Cloth Plus est fabriqué avec une texture unique, ouverte et ondulée qui permet la collecte efficace de toutes les particules de saleté. Facile à rincer et à sécher rapidement. Le chiffon reste propre et hygiénique pendant longtemps.

J-Cloth Plus

O pano J-Cloth Plus é fabricado com uma textura única, aberta e ondulada que permite a recolha eficiente de qualquer partícula de sujidade. Fácil de enxaguar e secar rapidamente. O pano permanece limpo e higiénico por muito tempo.

J-Cloth Plus

The J-Cloth Plus cloth is made of a unique, open and wavy texture that allows efficient collection of any dirt particles. It is easy to rinse and dries quickly. The cloth remains clean and hygienic for a long time.



	Color	Size cm	Pack x Box	Box x Pallet
NEW 0074501 J-CLOTH PLUS BLANCO	White	51x36	50 x 10	36

Lavette Super

Es un paño de limpieza completo, multifuncional, absorbente, resistente y duradero. No se rompe fácilmente y se puede usar de forma reiterada, garantizando una absorción perfecta y una excelente recogida de las partículas más duras. Fácil de enjuagar y se seca rápidamente.

Lavette Super

Ce chiffon de nettoyage permet de nombreuses performances. Il est multifonctionnel, absorbant, résistant et durable. Il ne se casse pas facilement et peut être utilisé à plusieurs reprises, tout en assurant une absorption parfaite et une excellente collecte des particules les plus dures. Facile à rincer et séchage rapide.

Lavette Super

É um pano de limpeza completo, multifuncional, absorvente, resistente e duradouro. Não se rasga facilmente e pode ser utilizado de forma reiterada, garantindo uma absorção perfeita e uma excelente recolha das partículas mais duras. Fácil de lavar e enxaguar e seca-se rapidamente.

Lavette Super

A very versatile, multifunctional cloth that is absorbent, strong and long-lasting. It does not break easily and can be used over and over again, guaranteeing perfect absorbency and excellent collection of particles. Easy to rinse and quick-drying.



	Color	Size cm	Pack x Box	Box x Pallet
0074464	○	51x36	6 x 25	48
0074465	●	51x36	6 x 25	48
0074466	●	51x36	6 x 25	48
0074467	●	51x36	6 x 25	48
0074468	●	51x36	6 x 25	48
0074530	●	51x36	16 x 10	36

Microfibre Plus

La composición única de Microfibre Plus proporciona una excelente limpieza libre de marcas y es perfecto para utilizar en vidrios, en acero inoxidable, espejos y pantallas táctiles. 100% higiénico.

Microfibre Plus

La composition unique de Microfibre Plus ournit un nettoyage excellent sans laisser de traces. Il sera utilisé pour le nettoyage des vitres, de l'acier inoxydable, des miroirs et des écrans tactiles. 100 % hygiénique.

Microfibre Plus

A composição única de Microfibre Plus proporciona uma excelente limpeza livre de marcas e é perfeito para utilizar em vidros, aço inoxidável, espelhos e ecrãs tácteis 100% higiénico.

Microfibre Plus

Microfibre Plus s unique composition provides excellent cleaning that leaves no marks: perfect for use on glass, stainless steel, mirrors and touchscreens. 100% hygienic.



	Color	Size cm	Pack x Box	Box x Pallet
0074721	●	34x40	24 x 5	112
0074723	●	34x40	24 x 5	112
0074724	●	34x40	24 x 5	112

MATERIAL TÉCNICO · MATÉRIEL TECHNIQUE · MATERIAL TÉCNICO · TECHNICAL MATERIAL · MATERIAL TÉCNICO

Multipurpose Super

Es un paño indispensable en las cocinas y resistente a los disolventes empleados en la limpieza industrial.

Gran capacidad de absorción: absorbe 9 veces su propio peso. No se rompe fácilmente y es resistente al calor (250° C): su estructura y espesor lo hace apto para el manejo de platos calientes.

Multipurpose Super

Ce chiffon est indispensable pour les cuisines, il résiste aux solvants employés pour le nettoyage industriel.

Grande capacité d'absorption: il absorbe 9 fois son propre poids. Il ne se casse pas facilement et résiste à la chaleur (250° C) : grâce à sa structure et son épaisseur, son utilisation est recommandée pour la manipulation de plats chauds.

Multipurpose Super

É um pano indispensável nas cozinhas e resistente aos dissolventes utilizados na limpeza industrial.

Grande capacidade de absorção: absorve 9 vezes o seu próprio peso. Não se rasga facilmente e é resistente ao calor (250° C): a sua estrutura e espessura tornam-no apto para o manejo de pratos quentes.

Multipurpose Super

An indispensable cloth for kitchens capable of withstanding the solvents used in industrial cleaning.

Extremely absorbent: absorbs nine times its own weight. Does not break easily; heat resistant (to 250° C): its structure and thickness make it ideal for handling hot dishes.

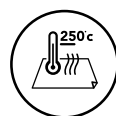

0074711



0084608



0084609

	Color	Size cm	Content	Box x Pallet
0074711	●	34x53	1 box 130 wipes	72
0084609	○	40x32	1 roll 500 wipes	30
0084608	●	40x32	1 roll 500 wipes	30
0074712	○	34x53	1 box 130 wipes	72

Coffee Towel

El primer paño de limpieza diseñado para las máquinas de café. Resistencia superior a las altas temperaturas (hasta 250°).

Certificado ISO 12127 Estructura abierta para un mejor recogida de partículas. Más fácil de enjuagar y reutilizable. Lavable a máquina para su uso repetido.

Coffee Towel

Le premier chiffon de nettoyage conçu pour les machines à café. Résistance supérieure aux températures élevées (jusqu'à 250° C).

Certification ISO 12127 Structure ouverte pour une meilleure collecte des particules. Plus facile à rincer et réutilisable. Lavable en machine pour un usage répété.

Coffee Towel

O primeiro pano de limpeza concebido para máquinas de café. Resistência superior às altas temperaturas (até 250°). Certificado pela norma ISO 12127. Estrutura aberta para uma melhor recolha das partículas. Mais fácil de lavar e enxaguar e reutilizável. Lavável à máquina para um uso repetido.

Coffee Towel

The first cleaning cloth designed for coffee machines. Superior resistance to high temperatures (up to 250°). ISO 12127 certified Open structure to allow better collection of particles. Easy to rinse and reusable. Machine washable for repeated use.



0074717

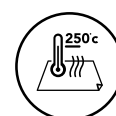

	Color	Size cm	Content	Box x Pallet
0074717	●	43x32	20 bags x 10 wipes	42

Microfibra Light Cloth El rendimiento en la limpieza del Microfib a light de Chicopee es superior a la de los paños de microfibr a tejida tradicional, al mismo tiempo que elimina el riesgo de contaminación cruzada. Diseñado para ser utilizado en un periodo de tiempo corto, no requiere lavado, lo que permite ahorrar tiempo y mejorar las prácticas de higiene mientras remueve el 99.99% de las bacterias.

Microfibre Light Cloth Les performances de nettoyage supérieures du chiffon Microfibre Light de Chicopee sont équivalentes à celle des chiffons traditionnels en microfibre tissée, tout en éliminant le risque de contamination croisée. Conçu pour un usage à court terme, il ne nécessite pas de lavage, ce qui permet d'économiser du temps et d'améliorer les pratiques en matière d'hygiène tout en éliminant toujours 99,99% des microbes.

Microfibre Light Cloth Chicopee Microfiber Light Cloth fornece a mesma performance superior na limpeza que as tradicionais microfibras de tecido, no entanto sem o risco de contaminação cruzada. Desenhado para um uso de curta duração, elimina a necessidade de lavar os panos, economizando tempo e melhorando as práticas de higiene, enquanto que remove 99,99% de microbios.

Microfibre Light Cloth Microfibre Light cloth provides the same superior cleaning performance as traditional woven microfibre cloths without the risk of cross contamination. Designed for short term use, it removes the need to launder cloths therefore saving time and improving hygiene practices while still removing 99.99% of microbes.

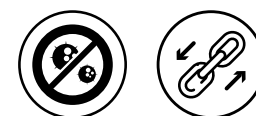

	Color	Size cm	Content	Box x Pallet
0074733		34x40	40 wipes	8



Veraclean Critical Cleaning Plus

La fuerza para realizar cualquier trabajo. Súper-resistente, tanto húmedo como seco: No se rompe con el uso.
 Alta absorción, elimina fluidos inmediatamente con un efecto de secado instantáneo.
 Sin silicona: Adecuado para cualquier industria.
 Baja pérdida de pelusas.

Veraclean Critical Cleaning Plus

La force pour exécuter n'importe quel travail. Super résistant, humide ou sec : il ne se casse pas en l'utilisant.
 Haute absorption, élimine les liquides immédiatement avec un effet de séchage instantané.
 Sans silicone : convient à toutes les industries. Faible perte de peluches.

Veraclean Critical Cleaning Plus

A força para realizar qualquer trabalho. Super-resistente, tanto húmido como seco: Não se rasga com o uso. Alta absorção, elimina fluidos imediatamente com um efeito de secagem instantânea.
 Sem silicone: adequado para qualquer indústria. Baixa perda de partículas.

Veraclean Critical Cleaning Plus

Strong enough for any job. Ultra-resistant, wet or dry Does not break with use. Highly absorbent. Eliminates fluids immediate y with an instant drying effect. Silicone-free: Suitable for any industry. Low fibre loss Lint-free, absorbent and strong



	Color	Size cm	Content	Box x Pallet
0084575	○	37x29	1 roll x 400 wipes	75
0084562	●	37x29	1 roll x 400 wipes	75

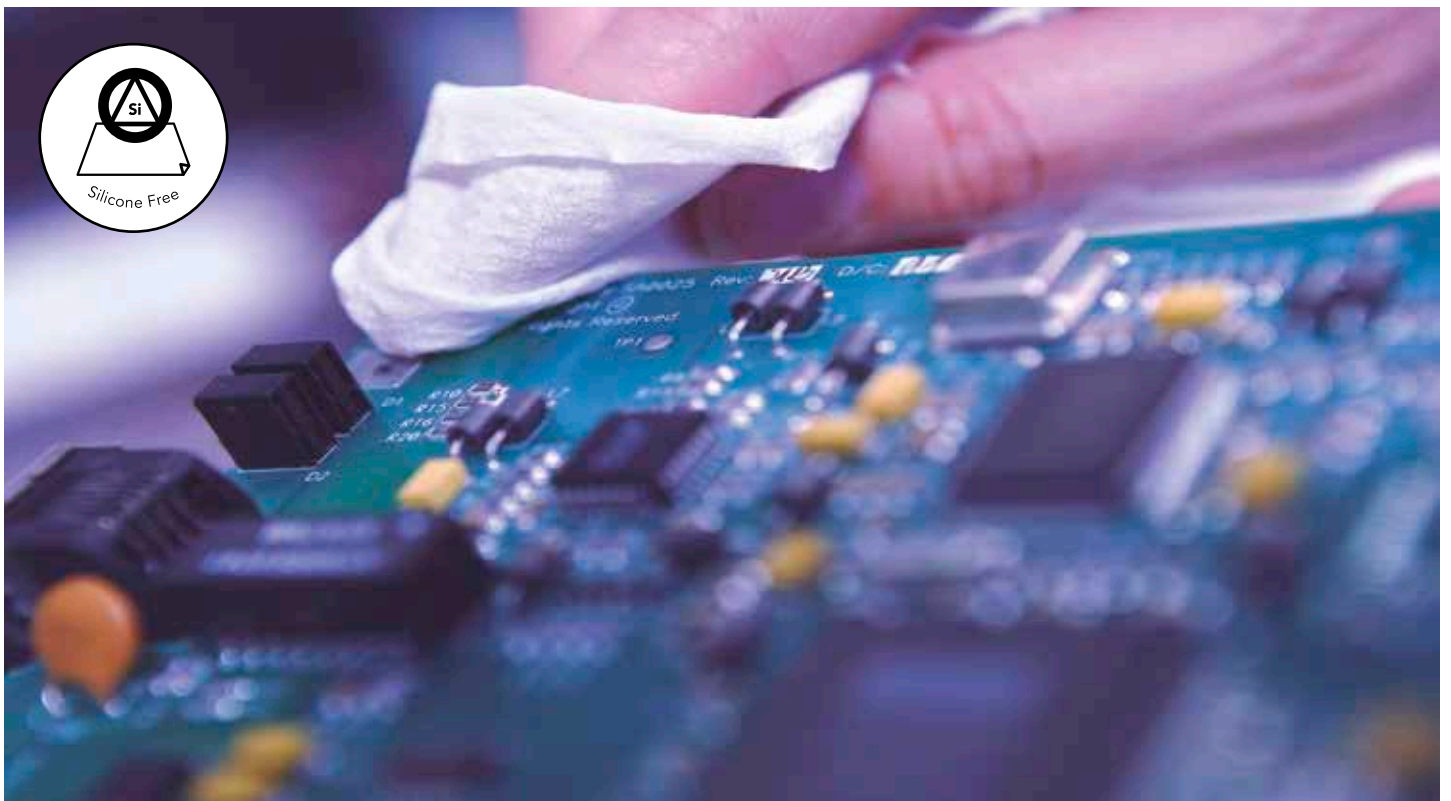

Durawipe

Ideal para limpieza industrial, desde el secado de manos a la limpieza de maquinaria o superficies. Resistente a roturas y duradero, permite múltiples usos. Muy absorbente, idóneo para su uso en húmedo porque no se desintegran y permanecen intactos. Pueden usarse con detergentes y disolventes.

Durawipe

Idéal pour le nettoyage industriel, du séchage des mains au nettoyage des machines ou des surfaces. Résistant à la casse et durable, il permet de multiples utilisations. Très absorbant, idéal pour une utilisation humide car il ne se désagrège pas et reste intact. Des détergents et des solvants peuvent être utilisés.

Durawipe

Ideal para a limpeza industrial, desde a secagem de mãos à limpeza de maquinarias ou superfícies. Resistente a rupturas e duradouro, permite múltiplas utilizações. Muito absorvente, ideal para o uso em superfícies húmidas porque não se desintegra e permanece intacto. Pode ser utilizado com detergentes e dissolventes.

Durawipe

Ideal for industrial cleaning, from hand drying to the cleaning of machinery or surfaces. Resistant to breakages and long-lasting, it withstands multiple uses. Very absorbent: ideal for wet use as it does not disintegrate, remaining fully intact. Can be used with detergents and solvents.

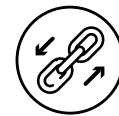

	Color	Size cm	Content	Box x Pallet
0084586 Light	○	37x22	2 roll x 175 wipes	84
0084582 Plus	○	37x33	1 roll x 300 wipes	50
0084580	○	37x22	1 roll x 300 wipes	60

Strech´Dust

La mopa está diseñada para la limpieza de suelos secos en multitud de entornos y cada mopa puede limpiar una habitación individual de alrededor de 15 m². Impregnados de aceite para garantizar la recogida de polvo y suciedad de forma óptima. Desechables para evitar el riesgo de contaminación.

Strech´Dust

La serpillière est conçue pour nettoyer les sols secs dans divers milieux. Chaque serpillière peut nettoyer une pièce individuelle d'environ 15 m². Imprégnée d'huile pour assurer une collecte optimale de la poussière et de la saleté. Jetable pour éviter le risque de contamination.

Strech´Dust

A mopa foi concebida para a limpeza de pisos secos numa infinidade de ambientes e cada mopa pode limpar um compartimento individual de, aprox., 15 m². Humedecidas com óleo para garantir uma recolha optimizada de poeiras e sujidade. Descartáveis para evitar o risco de contaminação.

Strech´Dust

This mop duster is designed for cleaning dry floors in a wide range environments. Each duster can clean a single room measuring approximately 15m². Impregnated with oil to guarantee optimal dirt and dust collection. Disposable: avoids risk of contamination.



	Color	Size cm	Content	Box x Pallet
0073302	●	60x19	20 bags x 50 wipes	70

S.U.D.S.

Le permite crear un paño impregnado que se ajusta exactamente a sus necesidades. Inserte el rollo de paños desechables en el cubo y añada su propio producto químico para crear al instante un paño húmedo, económico y de gran rendimiento. La impregnación bajo demanda reduce el riesgo de caducidad química y mejora la eficiencia

S.U.D.S.

Vous permet de créer un tissu imprégné qui correspond exactement à vos besoins. Insérez le rouleau de lingettes jetables dans le seau et ajoutez votre propre produit chimique pour créer instantanément un chiffon humide performant et peu coûteux. L'imprégnation à la demande réduit le risque d'expiration chimique et améliore l'efficacité

S.U.D.S.

Permite criar um pano impregnado que atenda exatamente às suas necessidades. Insira o rolo de lenços descartáveis no balde e adicione seu próprio produto químico para criar instantaneamente um pano úmido e de alto desempenho. A impregnação sob demanda reduz o risco de expiração química e melhora a eficiência

S.U.D.S.

Allows you to create an impregnated wipe that exactly matches your needs. Insert the roll of disposable wipes into the bucket and add your own chemical to instantly create a high-performance, inexpensive, damp wipe. Impregnating on demand reduces risk of chemical expiration & improves efficiency .



8462200



	Color	Size cm	Content	Box x Pallet
8462200	○	17x23 cm	200 wipes x 6 rolls + dispenser bucket	40



Code	Descripción / Colour	Format	Size cm	Wipes per Package or Roll	Packets per box	Pallet boxes
J-CLOTH COMPOSTABLE						
0074441	J-Cloth Plus Biodegradable 	1/4	43x32	50	10	50
0074442	J-Cloth Plus Biodegradable, 	1/4	43x32	50	10	50
0074443	J-Cloth Plus Biodegradable 	1/4	43x32	50	10	50
0074444	J-Cloth Plus Biodegradable 	1/4	43x32	50	10	50
J-CLOTH PLUS						
0074501	J-Cloth Plus 	1/4	51x36	50	10	26
LAVETTE SUPER						
0074464	Lavette Super 	1/4	51x36	25	6	48
0074465	Lavette Super 	1/4	51x36	25	6	48
0074466	Lavette Super 	1/4	51x36	25	6	48
0074467	Lavette Super 	1/4	51x36	25	6	48
0074468	Lavette Super 	1/4	51x36	25	6	48
0074530	Lavette Super 10-Pack 	1/4	51x36	10	16	36
COFFEE TOWEL						
0074717	Coffee Towel 	1/4	43x32	10	20	42
MULTIPURPOSE						
0084608	Multipurpose Super, Cloth Roll 	Roll	40x32	500	1	30
0084609	Multipurpose Super, Roll 	Roll	40x32	500	1	30
0074711	Multipurpose Super (Distribution box) 	M	34x53	130	1	72
0074712	Multipurpose Super (Distribution box) 	M	34x53	130	1	72
DURAWIPE						
0084586	Durawipe Light, Disp. central, Roll 	Roll	37x22	175	2	84
0084582	Durawipe Plus, Roll 	Roll	37x33	300	1	50
0084580	Durawipe Light Disp. Roll 	Roll	37x22	300	1	60
VERACLEAN						
0084562	Veraclean Critical Cleaning Plus 	Roll EFP	37x29	400	1	75
0084575	Veraclean Critical Cleaning Plus 	Roll EFP	37x29	400	1	75
MICROFIBRELIGHT						
0074733	Microfibre Light Clot 	1/4	34x40	40	8	42
MICROFIBRE PLUS						
0074721	Microfibre Plu 	1/4	34x40	5	24	112
0074723	Microfibre Plu 	1/4	34x40	5	24	112
0074724	Microfibre Plu 	1/4	34x40	5	24	112
ECONOMY FLOOR						
0073302	Economy Floor wipe TH, oil 	Flat	60x19	50	20	70
SUDS						
8462200	Suds Microfib a Eco 	Roll + Bucket	17x23	200	6 rolls + 1 Bucket	40



Soluciones completas y sostenibles de higiene.

Des solutions d'hygiène complètes et durables
Soluções completas e sustentáveis de higiene
Complete and sustainable hygiene solutions

www.gcservice.es



100%
Recycled

DISPENSADORES HIGIENE
DISTRIBUTEURS HYGIENE
DISPENSADORES DE HIGIENE
SANITARY DISPENSERS

DISPENSADORES HIGIENE / DISTRIBUTEURS HYGIENE

DISPENSADORES HIGIENE / SANITARY DISPENSER

Higiénico Industrial / Papier Toilette Industriel / Higiénico Industrial / Industrial Toilet Paper



100%
Recycled

Dispensador Higiénico Industrial
Distributeur hygiénique industriel
Dispensador Higiénico Industrial
Industrial toilet tissue dispenser

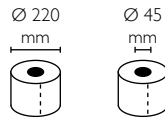

Ideal para aseos con tránsito elevado. Diseño funcional, se adapta a cualquier espacio.

Idéal pour les toilettes à forte fréquentation. Design fonctionnel, il s'adapte à tous les espaces.

Ideal para casas de banho com elevada afluência. Design funcional, adapta-se a qualquer espaço.

Ideal for toilets with high influx of people. Functional design suitable to all spaces.

		Dispenser Size
J288005	100% Recycled Plastic, white	274x270x115

6 U. x Box
Compatibility: With all jumbo rolls



100%
Recycled

Dispensador Higiénico Industrial
Distributeur hygiénique industriel
Dispensador Higiénico Industrial
Industrial toilet tissue dispenser

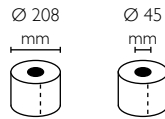

Dispositivo de fácil limpieza por sus formas curvas.

Dispositif facile à nettoyer grâce à ses formes courbes.

Dispositivo fácil de limpar pelas suas formas curvas.

Easy to clean thanks to its curved shape.

		Dispenser Size
J288007	100% Recycled Plastic, white Controlled dispensing	253x253x121

6 U. x Box
Compatibility: J287089



100%
Recycled

Dispensador Maxi Jumbo
Distributeur Maxi Jumbo
Dispensador Maxi Jumbo
Maxi Jumbo dispenser

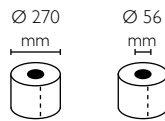

Ideal para aseos con tránsito intenso. Diseño funcional, se adapta a cualquier espacio. Fácil limpieza.

Idéal pour les toilettes à forte fréquentation. Design fonctionnel, il s'adapte à tous les espaces. Facile à nettoyer.

Ideal para casas de banho com elevada afluência. Design funcional, adapta-se a qualquer espaço. Fácil de limpar.

Ideal for toilets with intense traffic. Functional design suitable to all spaces. Easy to clean.

		Dispenser Size
J288009	100% Recycled Plastic, white	332x325x120

6 U. x Box
Compatibility: With all maxi jumbo rolls



Dispensador Higiénico Interplegado
Distributeur hygiénique enchevêtré
Dispensador Higiénico folha a folha
Hygienic dispenser for inter-folded toilet paper

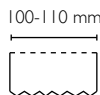

Compacto, robusto y con características antivandálicas. Para aseos con tránsito elevado e intenso.

Compact, robuste et aux caractéristiques évitant le vandalisme. Pour les toilettes à forte fréquentation.

Compacto, robusto e com características anti-vandalismo. Para casas de banho com elevada afluência.

Compact, resistant, anti-vandalism design. Ideal for toilets with high and intense influx of people.

		Dispenser Size
J287512	ABS plastic, white	295x140x140

1 U. x Box
Compatible with H303400 GC Interfolded

Toallas de Mano / Essuie-Mains Enchevêtrés / Toalhas de Mão / Hand Towels



100%
Recycled

Dispensador Toallas de Mano
Distributeur Essuie-Mains Enchevêtrés
Dispensador Toalhas de Mão
Hand Towels Dispenser



Dispensador compacto ideal para aseos con tránsito elevado e intenso. Capacidad: 600 toallas.

Distributeur compact, idéal pour les toilettes à forte fréquentation. Capacité : 600 essuie-mains enchevêtrés.

Dispensador compacto ideal para casas de banho com elevada afluência. Capacidade: 600 toalhas.

Compact dispenser ideal for toilets with high and intense traffic. Capacity: 600 towels.

		Dispenser Size
J288013	100% Recycled Plastic, white	271x360x121

8 U. x Box

DISPENSADORES HIGIENE / DISTRIBUTEURS HYGIENE DISPENSADORES HIGIENE / SANITARY DISPENSER

Secamanos Auto-corte / Essuie-mains Autocut / Seca-mãos Autocorte / Autocut Hand Towel



NEW!



Dispensador Simplicity Mini
Distributeur Simplicity Mini
Dispensador Simplicity Mini
Simplicity Mini Dispenser

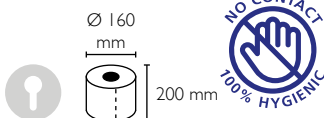

		Dispenser Size
J288539	Plastic, White	311x314x194

1 U. x Box
Compatible with J288420

100%
Recycled

Dispensador automático. Indicado para espacios reducidos. Distributeur automatique. Idéal pour les espaces réduits. Dispensador automático. Indicado para espaços reduzidos. Automatic dispenser. Suitable for small spaces.

NEW!



Dispensador Simplicity
Distributeur Simplicity
Dispensador Simplicity
Simplicity Dispenser

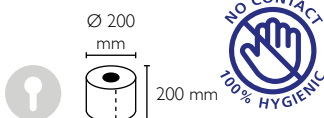

		Dispenser Size
J288538	Plastic, White	383x315x236

1 U. x Box
Compatible with all Autocut Hand Towel Roll

100%
Recycled

Automático y Autocorte. Dispositivo silencioso, corte automático sin pilas, uso racional y económico del papel. Automatique et Autocut. Dispositif silencieux, découpe automatique sans piles, utilisation rationnelle et économique du papier.

Automático e Autocorte. Dispositivo silencioso, corte automático sem pilhas, uso racional e económico do papel.

Automatic and autocut. Silent device, automatic cut with no need for batteries. Economical and rational use of paper.

NEW!



Dispensador Essence Electronic
Distributeur Essence Electronic
Dispensador Essence Electronic
Essence Electronic Dispenser

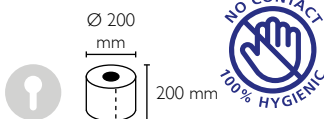

		Dispenser Size
J288537	Plastic, White	299X365X218

1 U. x Box
Compatible with all Autocut Hand Towel Roll

100%
Recycled



Teclado regulador
Clavier contrôleur
Teclado regulador
Controller keyboard

Secamanos
Maxi Mains
Seca-Mãos
Hand Towel

Dispositivo ajustable, universal, alta capacidad, compacto, resistente, bajo mantenimiento y 100% higiénico.

(Funciona con 4 pilas D) Teclado regulador de longitud del servicio y tiempo de dispensación. Dispositif ajustable, universel, haute capacité, compact, résistant, faible maintenance et 100 % hygiénique.

(Fonctionne avec 4 piles D). Clavier qui règle la longueur du format et le temps de distribution. Dispositivo ajustável, universal, alta capacidade, compacto, resistente, baixa manutenção e 100% higiénico. (Funciona com 4 pilhas D). Teclado regulador do comprimento a dispensar e do tempo de dispensação.

Adjustable, universal, high-capacity, compact, strong, low maintenance and 100% hygienic. (Works with 4 D size batteries) keypad for adjusting length of paper and dispensing time.

DISPENSADORES HIGIENE / DISTRIBUTEURS HYGIENE DISPENSADORES HIGIENE / SANITARY DISPENSER

Secamanos / Maxi-mains / Seca-mãos / Hand Towel Roll



100%
Recycled

Dispensador Secamanos
Distributeur Maxi-mains
Dispensador Seca-mãos
Hand towel dispenser

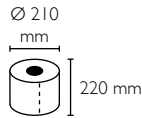

		Dispenser Size
J28801 I	100% Recycled Plastic, white	220x310x220

6 U. x Box
Compatible with all Hand Towel Roll

Diseño polivalente que se adapta a cualquier espacio. Ideal para aseos y cocinas con un tránsito elevado.

Design polyvalent qui s'adapte à tous les espaces. Idéal pour les toilettes et les cuisines à forte fréquentation.

Design polivalente que se adapta a qualquer espaço. Ideal para casas de banho e cozinhas com elevada afluência
Multipurpose design suited to all spaces. Ideal for toilets and kitchens with high influx of people.



Dispensador Mini Secamanos
Distributeur Mini Essuie-mains
Dispensador Mini Seca-mãos
Mini Hand towel dispenser

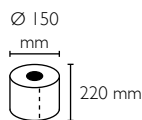

		Dispenser Size
J288501	ABS plastic, Fume	335x180x170

1 U. x Box
Compatible with all Mini Hand Towel Roll

Diseño compacto que se adapta en espacios reducidos. Ideal para aseos y cocinas con un tránsito medio.

Design compact qui s'adapte aux espaces réduits. Idéal pour les toilettes et les cuisines à moyenne fréquentation

Design compacto que se adapta a espaços reduzidos. Ideal para casas de banho e cozinhas com alguma afluência
Compact design suited to small spaces. Ideal for toilets and kitchens with average traffic.

Celulosa Industrial / Bobine Industrielle / Celulose Industrial / Industrial Cellulose



Dispensador de Celulosa Industrial
Distributeur Bobine industrielle
Dispensador de Celulose Industrial
Industrial cellulose Dispenser

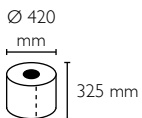

		Dispenser Size
J286501	Inoxidable / Stainless	400x420x380

1 U. x Box

Dispensador de pared, ideal para espacios exteriores, resistente a la humedad.

Distributeur mural, idéal pour les espaces extérieurs, résistant à l'humidité.

Dispensador de parede, ideal para espaços exteriores, resistente à humidade.
Wall dispenser perfect for outside spaces, damp-resistant.



Dispensador de Celulosa Industrial
Distributeur Bobine industrielle
Dispensador de Celulose Industrial
Industrial cellulose Dispenser

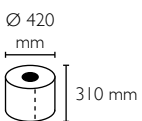

		Dispenser Size
J286500	Metallic/ Plastic	950x400x390

1 U. x Box

Dispensador de pie, robusto y compacto. Ideal para espacios exteriores, resistente a la humedad.

Distributeur sur pied, robuste et compact. Idéal pour les espaces extérieurs, résistant à l'humidité.

Dispensador de pé, robusto e compacto. Ideal para espaços exteriores, resistente à humidade.
Freestanding dispenser. Resistent and compact. Ideal for outdoor spaces, damp-resistant.



Dispensador de Celulosa Industrial
Distributeur Bobine industrielle
Dispensador de Celulose Industrial
Industrial cellulose Dispenser



		Dispenser Size
J288533	Plastic	400x330x330

1 U. x Box

Dispensador cerrado de pared extracción central controlada, con control del consumo. 100% higiénico, cerrado para evitar la contaminación.

Distributeur fermé à paroi d'extraction centrale contrôlée, avec contrôle de la consommation. 100% hygiénique, fermé pour éviter toute contamination.

Dispensador fechado de parede de extração central controlada, com controle de consumo. 100% higiénico, fechado para evitar contaminação.

Controlled central extraction wall closed dispenser, with consumption control. 100% hygienic, closed to avoid contamination.

DISPENSADORES HIGIENE / DISTRIBUTEURS HYGIENE DISPENSADORES HIGIENE / SANITARY DISPENSER

Rollo Camilla / Drap d'examen / Dispensadores rolo marquesa / Medical Roll



Dispensador rolo camilla
Distributeur draps d'examens
Dispensadores rolo marquesa
Medical Roll dispenser



		Dispenser Size
J289500	Metallic / Plastic	620x210

1 U. x Box

Resistente, compacto y de fácil instalación en camillas.
Résistant, compact et facile à installer sur les lits.
Resistente, compacto e de fácil instalação em macas.
Resistant, compact and easy to install on stretchers.



J289120

Dosificador Jabón / Distributeur de S von / Dispensador de sabão / Soap Dispenser



Dosificador de Jabón
Distributeur de Savon
Dispensador de sabão
Soap Dispenser



		Dispenser Size
J288015	100% Recycled Plastic, white	112x210x105

10 U. x Box

**100%
Recycled**

Se adaptan a cualquier espacio. Con visor frontal para visualizar el consumible de su interior:

Il s'adapte à tous les espaces. Avec une fenêtre de visualisation frontale pour voir le consommable à l'intérieur.

Adaptam-se a qualquer espaço. Com visor frontal para visualizar o consumível no seu interior.

Suitable to all spaces. With front viewing window to check levels of product.

Apto para productos hidralcohólicos. / Adapté pour les produits hydro-alcooliques.
Adequado para produtos hidralcohólicos. / Suitable for hydralcoholic products.

**PARA LA MESA
POUR LA TABLE
PARA A MESA
FOR THE TABLE**

ES GC Class es la marca de mantelería y servilletas de un solo uso, responsable medioambientalmente y diseñada exclusivamente para el canal profesional. Es una de las marcas más 'eco' de Gomà-Camps gracias a su amplia gama y oferta: todas las referencias son certificadas, libres de plásticos y fabricadas con tintas al agua, embalaje y papel compostables.

Disponible dos tipos de colecciones en función del tipo de material: Airlaid Collection y Spunlace Collection. Ambas gamas la forman productos de un solo uso con un tacto similar a la tela y su alta resistencia.

Ahora puedes consultar todas las propuestas para la mesa en nuestra plataforma [HYPERLINK www.gcexperience.es](http://www.gcexperience.es) donde podrás descubrir cómo convertir una mesa, en una mesa con estilo.

FR "GC Class la marque de nappes et serviettes à usage unique, éco-responsable, conçue exclusivement pour le canal professionnel. C'est l'une des marques les plus écologiques de Gomà-Camps avec sa gamme très vaste : toutes les références sont certifiées, elles sont sans plastique et la fabrication a lieu avec des encres à base d'eau, des emballages et du papier compostables."

Deux types de collections sont disponibles selon le type de matériel : Collection Airlaid et Collection Spunlace. Les deux gammes présentent de produits à usage unique avec un toucher similaire au tissu et une grande résistance.

Vous pouvez maintenant consulter toutes les offres sur notre plateforme www.gcexperience.es fr où vous pouvez découvrir comment transformer une table simple en une table avec classe.

PT GC Class é a marca de toalhas de mesa e guardanapos descartáveis, ambientalmente responsáveis e desenhadas exclusivamente para o canal profissional. É uma das marcas mais 'eco' da Gomà-Camps graças à sua vasta gama e oferta: todas as referências são certificadas, isentas de plásticos e fabricadas com tintas à base de água, embalagens compostáveis e papel.

Estão disponíveis dois tipos de coleções dependendo do tipo de material: Coleção Airlaid e Coleção Spunlace. Ambas as gamas são compostas por produtos descartáveis com um toque semelhante ao tecido e sua alta r

Agora pode conferir todas as propostas para mesa na nossa plataforma www.gcexperience.es onde você poderá descobrir como transformar uma mesa numa mesa com estilo.

EN GC Class is our environmentally responsible single-use tablecloth and serviette brand, designed exclusively for the professional channel. It is one of Gomà-Camps' greenest brands thanks to the wide range it offers: all the items in it are certified, plastic-free and made with water-based inks and compostable paper and packaging.

Two collections are available, corresponding to types of material: the Airlaid Collection and the Spunlace Collection. Both ranges are made up of very tough single-use products with a similar feel to fabric.

Now you can look up all our ideas for the table on our www.gcexperience.es platform, where you can find out how to turn a table into a stylish table.



GC[®]
Class
elegancia en tu mesa

Spunlace

COLLECTION



PACKAGING:
100%
PLASTIC FREE

MATERIAL:
SPUNLACE



100%
COMPOSTABLE

ES : Spunlace Collection es 100% compostable. Nuestra gama extra suave y más semejante a la tela, ahora fabricada con un nuevo material mucho más respetuoso con el medio ya que lo puedes compostar. Y además, tanto el envase como las tintas utilizadas en los diseños que te proponemos, son también compostables.

FR : la collection Spunlace est 100% compostable. Notre gamme extra douce semblable au tissu est désormais fabriquée avec un nouveau matériau plus respectueux de l'environnement car compostable. De plus, l'emballage et les encres utilisés pour les motifs que nos proposons sont également compostables.

PT : a coleção Spunlace é 100% compostável. A nossa linha extra macia e mais semelhante ao tecido, agora fabricada com novo material mais respeitoso com o meio ambiente, uma vez que é compostável. Além disso, tanto a embalagem como as tintas usadas nos desenhos propostos, são igualmente compostáveis.

EN : Spunlace Collection is 100% compostable. Our extra soft and fabric-like range, is now made with a new material much more respectful with the environment since you can compose it. In addition, both the packaging and the inks used in the designs that we propose, are also compostable.

COTTON

ES COTTON, da un toque de personalidad a la mesa. Nuevo diseño esencial con sensación tela de gran calidad ideal para tu negocio.

FR COTON, donne une touche de personnalité à la table. Nouveau design essentiel avec un tissu de haute qualité idéal pour votre entreprise.

PT COTTON, dá um toque de personalidade à mesa. Novo design essencial com tecido de alta qualidade ideal para o seu negócio.

EN COTTON, gives a touch of personality to the table. New essential design with high quality fabric feel ideal for your business.



T230120, T230121



T230120, R251198

Orgánico
 Soft **DOUCEUR**
 Silky **Suave**
 Géométrique
Textil **Organic**



T230122



40x40 cm

T230122

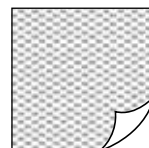

T230120

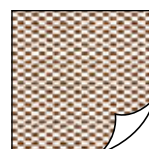

T230121

Like



Combinable
Combinável

- R251216
- R251218
- R251220

- R251216
- R251218
- R251120

- R251216
- R251218
- R251220



T230121



T230121, T230120, T230122

SPIGA

ES Crea un entorno estiloso y distinguido con este diseño de trama textil, ideal para cualquier local. Combínalos con diferentes tonos de mantelería Airlaid Collection.

FR Créez une ambiance élégante et distinguée avec ce motif à trame textile, parfaite pour tout type d'établissements. Combinez-les avec les différents tons des nappes de la collection Airlaid.

PT Crie um ambiente estiloso e diferenciado com este design de trama têxtil, ideal para qualquer local. Combine-as com as diferentes tonalidades dos jogos de mesa Airlaid Collection.

EN Create a stylish, distinguished setting with this textile weave design, ideal for any establishment. Combine them with different tones from the Airlaid Collection of tablecloths.



T230108









T230107, R251218

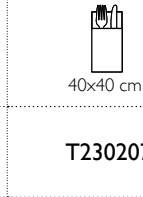

T230109, R251257

Orgánico
 Soft **DOUCEUR**
 Silky **Suave**
 Géométrique
Textil **Organic**

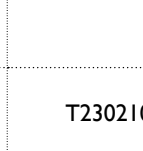
	 40x40 cm	 40x40 cm	Like Combinable Combinável ● R251216 ● R251218 ○ R251220
	 T230107	 T230207	
	 T230110	 T230210	● R251195 ● R251216 ● R251218



DOLCE

ES Su trama textil en colores suaves crea un diseño sencillo a la vez que original. Ideal para cualquier establecimiento o menú.

FR Sa trame textile aux couleurs douces crée un motif simple et original. Parfait pour tout type d'établissements ou menus.

PT A sua trama têxtil em cores suaves cria um design simples mas, ao mesmo tempo, original. Ideal para qualquer estabelecimento ou menu.

EN Its textile weave in soft colours creates a simple but original design. Ideal for any establishment or menu.



T230218, T230217, T230215, T230216,



T230218



T230215

LIGERO SUAVE Peaceful
 Soft Original Doce
 Élégant
DOUCE



T230117

T230217

- R251197
- R251216
- R251218

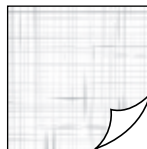

T230116

T230216

- R251220
- R251197
- R251218



GC
Class
elegancia en tu mesa



Airlaid COLLECTION



PACKAGING:
100%
PLASTIC FREE

MATERIAL:
AIRLAID



100%
COMPOSTABLE

ES Nuevos colores compostables que te ayudarán a hacer de tu negocio un lugar mejor para el medio ambiente. Nuestra colección Airlaid Collection está formada por servilletas y manteles en diferentes formatos, diseños y ahora también con colores compostables. Al igual que Spunlace Collection, el envase y las tintas utilizadas en los diseños que te proponemos son también compostables.

FR De nouvelles couleurs compostables qui vous aideront à faire de votre entreprise un allié pour l'environnement. Notre collection Airlaid est composée de serviettes et de nappes de différents formats, motifs et maintenant aussi avec des couleurs compostables. Comme pour la Collection Spunlace les emballages et les encres utilisés dans les motifs que nous vous proposons sont également compostables.

PT Novas cores compostáveis que ajudarão a tornar a sua empresa um lugar melhor para o meio ambiente. A nossa coleção Airlaid é composta por guardanapos e toalhas de mesa em formatos distintos, desenhos e agora também com cores compostáveis. Como a Spunlace Collection, a embalagem e as tintas usadas nos desenhos que lhe propomos também são compostáveis.

EN New compostable colors that will help you make your business a better place for the environment. Our Airlaid Collection is composed by napkins and tablecloths in different formats, designs and now also with compostable colors. Just like in our Spunlace Collection, the packaging and the inks used in the designs that we propose, are also compostable.

BISTROT

ES Este diseño hará sentir a tus comensales como si estuvieran en su casa.

FR Ce motif donnera à vos invités l'impression d'être chez eux.

PT Este design fará os seus convidados sentirem-se como se estivessem em casa.

EN This design will make your clients feel right at home.



T000706 - W000706



T000705 - W000705



T000707 - W000707

Calma
Familiar
Tradicional
Hogareño
familier
HOGAR
Handmade
Calme



40x40 cm

T000707



40x40 cm 1/8

T000708



30x40 cm

W000707

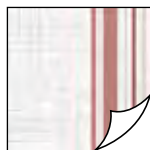

T000706

-

W000706

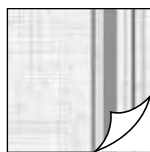

T00705

-

W000705

Like

Combinable
Combinável

● R251198

○ R251220

● R251218

● R251195

○ R251220

● R251218

● R251216

● R251218

○ R251220

COTTAGE

ES Servilleta idónea para menús caseros, tradicionales, que te ayudará a crear una ambiente acogedor: su tacto extra suave no dejará indiferente a tus clientes.

FR La serviette convient aux menus traditionnels faits maison, ce qui vous aidera à créer une atmosphère chaleureuse : son toucher extra doux ne laissera pas vos invités indifférents.

PT Guardanapo adequado para menus caseiros e tradicionais, que o ajudarão a criar um ambiente acolhedor: o seu toque extra suave não deixará os seus convidados indiferentes.

EN Ideal napkin for traditional and homemade menus. It will help you create a cozy atmosphere and its extra soft feel, will not leave your guests indifferent.



T000709



T000709, R251217



T000709, R251217

Orgánico
Soft DOUCEUR
Suave
Géométrique
Textil Organic

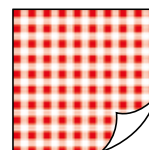

40x40 cm

T000709

Like

Combinable
Combinável

● R251217

● R251216

● R251197





experience

www.gcexperience.es

CONVIERTE TU MESA EN UNA EXPERIENCIA

VISITA NUESTRA PLATAFORMA PARA EL CANAL HORECA



DATE UNA VUELTA POR NUESTRO SHOWROOM VIRTUAL

FAÇA UM TOUR EM NOSSO SHOWROOM VIRTUAL

FAITES UNE VISITE DE NOTRE SHOWROOM VIRTUELLE

TAKE A TOUR OF OUR VIRTUAL SHOWROOM

MANDALA

ES Modelo geométrico basado en la estructura de una flor; adecuada para cualquier establecimiento y época del año.

FR Modèle géométrique basé sur la structure d'une fleur; adapté à tous les établissements et toutes les périodes de l'année.

PT Modelo geométrico baseado na estrutura de uma flor; adequado para qualquer estabelecimento e época do ano.

EN A geometrical model based on the structure of a flower; suitable for any establishment and time of year.



T221524 / R000208



T221500, R251254



T221501

Floral Attractant
Actual
Fresco Fresh
Elegante
Mosaico



40x40 cm

T221500



40x40 cm

T221502

Like

Combinable

Combinável

R251220

R251197

R251218

R251198

R251218

R251220



T221501

T221503



T221524

T221525

R251216

R000208

R251220

PARIS

ES Diseño atemporal que da un toque diferenciador y elegante para cualquier ambiente.

FR Ce motif original et intemporel apporte à toute ambiance une touche chic et unique.

PT Design original e atemporal que confere um toque diferenciador e elegante a qualquer ambiente.

EN A timeless original design to give a smart, distinctive touch to any setting.



T221452, R251217



T221457, R251216



T221452, R251217



T221457, R251216

Original Timeless
Atemporal Selecto
Vital Select Vivo



40x40 cm

T221452

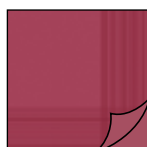

T221457

Like



Combinable

Combinável

R251216

R251220

R251197

R251216

R251220

R251197

MAISON

ES Traslada a tus comensales al calor del hogar con nuestro nuevo diseño Maison: servilletas agradables al tacto en diferentes tonalidades de líneas suaves.

FR Transmettez à vos clients la chaleur du foyer avec notre nouveau modèle design Maison : des serviettes agréables au toucher en différentes tonalités de lignes douces.

PT Transporte os seus convidados para o calor do lar com o nosso novo desenho Maison: Guardanapos de toque agradável em diferentes tonalidades de linhas suaves.

EN Make your dinner guests feel like at home with our new Maison design: Napkins in different shades and soft texture.



T221516, T221519, V230405



T221518, T221521



T221520

absorção
style
doux suave
Sensação de tecido
hogareño
Fraîcheur

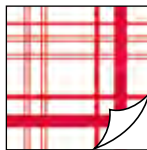

T221516

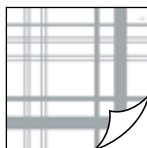

T221517

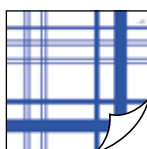

T221518



40x40 cm

T221519

Like



Combinable

Combinável

R251217

R251220

R251197

R251197

R251220

R251223

R251198

R251220

R251197

FILUM

ES Filum te ofrece una gran amplitud de posibilidades para decorar tu establecimiento. Escoge y combina diferentes colores y formatos.

FR Avec Filum vous disposez d'un large assortiment pour décorer votre établissement. Choisissez et combinez différents formats et couleurs.

PT Filum oferece inúmeras possibilidades para decorar o seu estabelecimento. Escolha e combine diferentes cores e formatos.

EN Filum offers you a wide range of possibilities to decorate your establishment. Mix and match different colours and formats.



Servilletas Filum / Serviettes Filum / Guardanapos Filum / Filum napkins

Hogar Atemporal
 Versátil
 Colorido Classico
 HOME Texture
 Tela

Piedra
 Pierre
 Pedra
 Stone

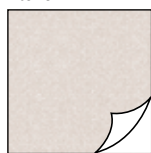

Kiwi
 Kiwi
 Kiwi
 Kiwi

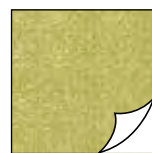





Turquesa
 Turquoise
 Turquesa
 Turquoise



Azul
 Bleu
 Azul
 Blue



 33x40 cm	T000244	-	-	-
 40x40 cm	T000213	T000202	-	T000205
 40x40 cm	T000214	T000208	T000231	T000211
 0,40x50 m	R000207	-	-	R000205

Airlaid COLLECTION



T000244, T00241, T000242, T00243



T000243



T000231

Burdeos
Bordeaux
Bordeaux
Burgundy

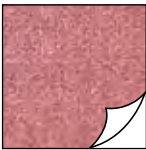

Cacao
Cacao
Cacau
Cocoa

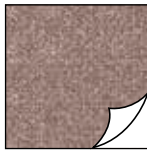

Grafit
Graphite
Grafit
Graphite







Negro
Noir
Preto
Black



Oro
Or
Ouro
Gold



 33x40 cm	T000242	T000243	T000241	-	-
 40x40 cm	T000203	T000204	T000229	T000201	T000222
 40x40 cm	-	T000210	T000232	T000207	T000223
 0,40x50 m	-	R000204	R000211	R000201	R000208

LUXE

ES Diseño tradicional suave y fino , adaptable a todos los tipos de establecimiento.

FR Motif traditionnel, doux et fin qui s'adapte à tous les types d'établissements.

PT Design tradicional delicado e fino , adaptável a todos os tipos de estabelecimento.

EN A soft, fine traditional design that fits into establishments of all kinds.

Smoothness
Diseño Design
 Blanco
Tradicional **Esencial**
 Fino TRADITIONNEL



T221436, R251246



40x40 cm

T221436



Combinable
Combinável

● R251216

● R251218

○ R251197

SIDNEY

ES Pinceladas de líneas redondeadas y circulares que muestran la elegancia del local.

FR Des touches aux lignes arrondies et circulaires qui témoignent de l'élégance des lieux.

PT Pinceladas em linhas arredondadas e circulares que mostram a elegância do local.

EN Brushstrokes in rounded, circular lines to bring out the elegance of the establishment.

Atemporal **Circulaire**
Elegancia
Versatile **L'élégance**



40x40 cm

T260001



Combinable
Combinável

● R251216

○ R251220

● R251217



40x40 cm

T260002



Combinable
Combinável

● R251216

○ R251220

○ R251197

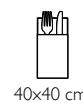
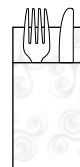

40x40 cm

T260000



Combinable
Combinável

● R251216

○ R251220

● R251217

SIENA

ES Cenefa de estilo barroco y de inspiración romántica. Para dar un toque clásico y elegante a cualquier espacio.

FR Une trame de style baroque et d'inspiration romantique, qui apporte à tout espace une touche classique et élégante.

PT Orla em estilo barroco e de inspiração romântica. Para dar um toque clássico e elegante a qualquer espaço.

EN A baroque-style border, romantic in its inspiration. To give a smart, classic touch to any setting.



T000506, R251216



T221443, R251216



T221440

ROMÁNTICO

DISTINGUIDO
Ornamental Delicado
Baroque
Elegante
Romantique

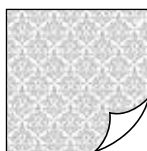

40x40 cm

T221442



40x40 cm

T000506

Like



Combinable

Combinável

R251218

R251220

R251197

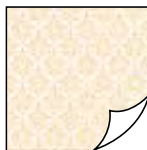

-

T000507

R251219

R251220

R251197



T221440

T000505

R251218

R251220

R251197

CENEFAS

ES Modelos de cenefas clásicas, un pequeño toque de diseño sobre fondo liso blanco.

FR Des modèles aux bordures classiques, qui apportent une petite touche de design sur une serviette blanche unie.

PT Modelos com orlas clássicas, um pequeno toque de design sobre guardanapo liso e branco.

EN Classic borders to add a touch of design to plain white napkins.



T221444



T221444, R251216



T221447



T221447

Classique **Clásico** **Classic**
Polyvalent
Versátil **Guirnalda**

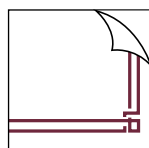

40x40 cm

T221447

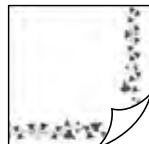

T221444

Like

Combinable
Combinável

● R251195

● R251218

○ R251197

● R251216

○ R251220

○ R251197

FLEUR

ES Diseño floral y geométrico en dos tonalidades. Modelo muy versátil para cualquier celebración y momento del año.

FR Motif floral et géométrique en deux tonalités. Ce modèle est très polyvalent pour tout type de fête et toutes les périodes de l'année.

PT Design floral e geométrico em duas tonalidades. Modelo muito versátil para qualquer celebração e momento do ano.

EN A geometrical floral design in two shades. A highly versatile model for any celebration and time of year.



T221507, R000208



T221504, R000208, R251195



T221504, R251195

Floral
Frais Alegórico
Versátil
FRESH
Polyvalent
Versatile

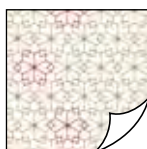

40x40 cm

T221504



40x40 cm

T221507

Like



Combinable
Combinável

● R251195

● R000208

● R251216













Color

ES ;Novedad! Ahora disponemos de más colores compostables, para que transmitas a tus clientes tu compromiso con el medioambiente y la sostenibilidad. Disfruta de nuestra amplia paleta de colores Airlaid en diferentes medidas en servilletas y manteles. Escoge en función de cada temporada, menú o evento los colores que te ayuden a crear un ambiente único. Combina también con nuestros diseños GC Class para un entorno mucho más Premium.

FR Nouveauté! Notre gamme de couleurs compostables s'est agrandie afin que vous puissiez transmettre à vos clients votre engagement envers l'environnement et la durabilité. Profitez de nos serviettes et nappes Airlaid dans une ample palette de couleurs en différents formats. Choisissez selon la saison, le menu ou l'événement les couleurs qui vous aident à créer une atmosphère unique. Combinez-les également avec notre gamme GC Class pour une ambiance encore plus "haut de gamme"!

PT ;Novidade! Agora dispomos de mais cores compostáveis, para que transmita aos seus clientes o seu compromisso com o meio ambiente e a sustentabilidade. Desfrute da nossa ampla paleta de cores Airlaid em diferentes medidas tanto em guardanapos como toalhas de mesa. Escolha em função de cada temporada, menu ou evento as cores que ajudem a criar um ambiente único. Combine também com os nossos desenhos GC class para um ambiente muito mais Premium.

EN ;New! We have availability of more compostable colors. Like that you can transmit to your clients your commitment with the environment and sustainability. Enjoy our wide range of Airlaid colors in different sizes. Choose depending on each season, menu or event. Our colors will help you creating an unique environment. Combine them with our GC Class designs in order to create a Premium feel.

			Blanco Blanc Branco White	Gris Gris Cinza Gray	Caramel Ivoire Caramelo Caramel	Rojo Rouge Vermelho Red	Lima Rouge Vermelho Red	Mandarina Rouge Vermelho Red
	Kangur Kangourou Kangur Kangaroo	 40x40 cm	T260021	T260007	T260009	T260013	T260028	T260029
	Servilleta Serviette Guardanapos Napkins	 40x40 cm	T224050	T224062	T224054	T224051	T224068	T224069
	Mantel Nappes Toalhete Tablecloths	 30x40 cm	W230099	-	-	-	-	-
	Dueto Chemins de table Dueto Dueto	 0,40x50 m	R251243	-	R251248	-	-	-
	Rollo Mantel Rouleaux de nappe Rolo toalha Roll tablecloth	 1,20x50 m	R251197	-	R251219	-	-	-
	Mantel Nappes Toalhete Tablecloths	 35x47 m	W230096	-	-	-	-	-











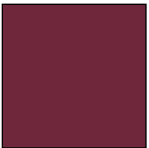

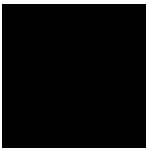

Airlaid COLLECTION



T264067, T260027

Personalizadas / Personnalisable
Personalizados / Customized



			Azul Bleu Azul Blue	Burdeos Bordeaux Bordeaux Burgundy	Cacao Cacao Cacao Cocoa	Grafit Graphite Grafit Graphite	Negro Noir Preto Black	Nature
								
	40x40 cm		T260014	T260004	T260008	T260010	T260003	T260027
	40x40 cm		T224055	T224057	T224059	T224063	T224052	T224067
	30x40 cm		-	-	-	-	W230405	W230097
	0,40x50 m		R251244	R251242	R251249	R251257	R251246	R251267
	1,20x50 m		R251198	R251195	R251218	-	R251216	-

ARIA (XL SIZE)

ES Crea un ambiente distinguido con nuestra servilleta de gran formato sensación tela. Da un toque selecto a tus mesas con el diseño Aria: flo al y sofisticado ideal pa a celebraciones.

FR Créez une atmosphère distinguée avec notre grande serviette en tissu au toucher. Donnez une touche sélective à vos tables avec le design Aria: flo al et sophistiqué, idéal pour les fêtes.

PT Crie uma atmosfera distinta com o nosso guardanapo de tecido grande. Dê um toque seletto às suas mesas com o design Aria: flo al e sofisticad , ideal para celebrações.

EN Create a distinguished atmosphere with our large fabric feel napkin. Give a select touch to your tables with the Aria design: flo al and sophisticated, ideal for celebrations.



T224041



T224041, R00208



T224041



T224041

Sofisticado Elegant
Textile Festivo **Suave**
Floral Célébration **Textil**



47x47 cm

T224041

Like

Combinable
Combinável

● R251216

● R000208

○ R251197



Special Sizes

XL SIZE

ES Disponemos de un amplio muestrario de productos en medidas especiales para adaptarnos a tus necesidades.

FR Un large éventail de produits est disponible dans des tailles spéciales pour nous adapter à vos besoins.

PT Dispomos de um vasto mostruário de produtos com medidas especiais que permite adaptarmo-nos às suas necessidades.

EN We have a wide range of samples of products in special sizes to meet your needs.



T224047

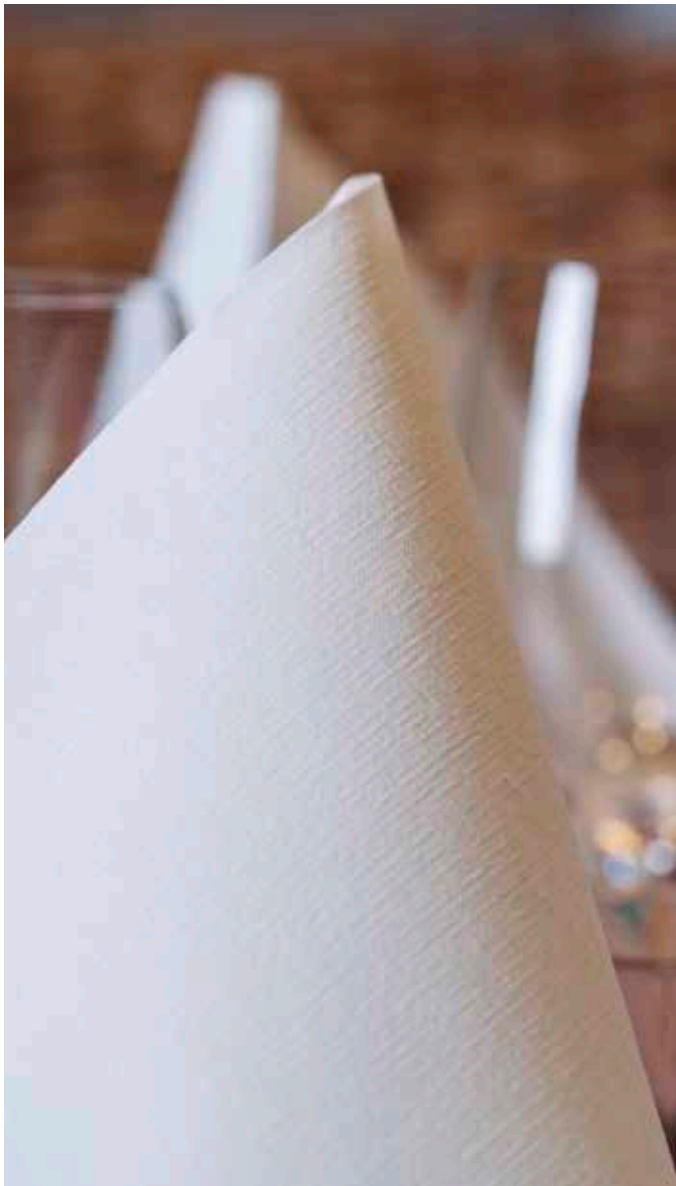

T224047

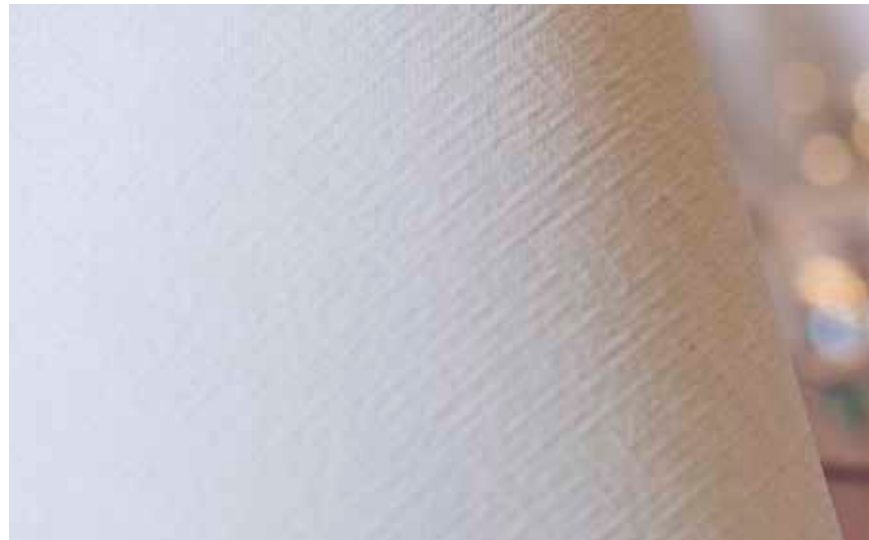

Big Tela
Trama
Eventos
Textile
XL
Celebración

Blanco
Blanc
Branco
White

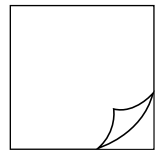

XL SIZE



47x40 cm
1/4

T224740



47x47 cm
1/8

T224042



47x47 cm
1/4

T224047

Special Sizes



T000246



T000246



T261121

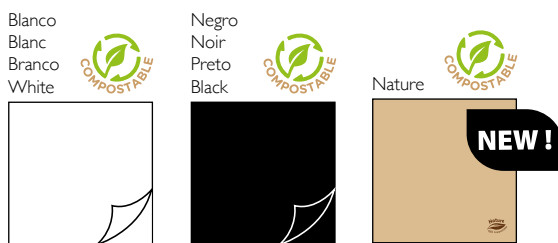

MINISIZE

	30x40 cm 1/6		T261121	-	-
	33x40 cm		T000245	T000246	T000248
	34x40 cm		T261125	-	-
	40x40 cm 1/8		T260018	T260019	-

Servilleta / Serviette / Guardanapos / Napkins

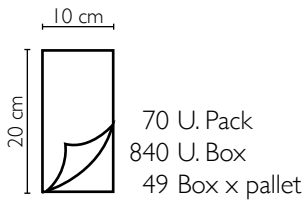

70 U. Pack
840 U. Box
49 Box x pallet

30x40 cm 1/6

Servilleta
Serviette
Guardanapos
Napkins

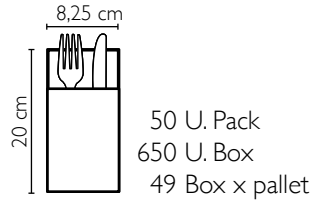

50 U. Pack
650 U. Box
49 Box x pallet

33x40 cm

Mini Kangur
Mini kangourou
Mini Kangur
Mini Kangur

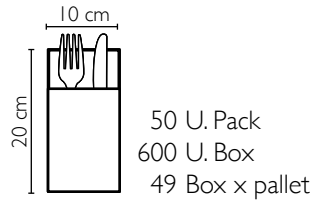

50 U. Pack
600 U. Box
49 Box x pallet

34x40 cm

Kangur
kangourou
Kangur
Kangur

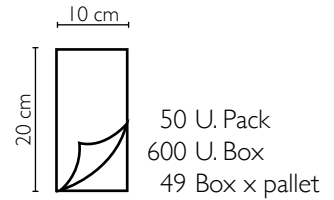

50 U. Pack
600 U. Box
49 Box x pallet

40x40 cm 1/8

Servilleta
Serviette
Guardanapos
Napkins

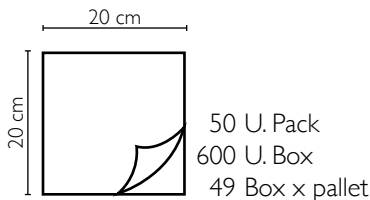

50 U. Pack
600 U. Box
49 Box x pallet

40x40 cm

Servilleta
Serviette
Guardanapos
Napkins

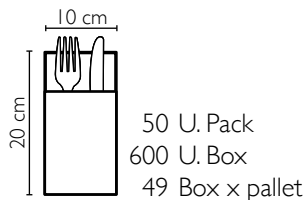

50 U. Pack
600 U. Box
49 Box x pallet

40x40 cm

Kangur
kangourou
Kangur
Kangur

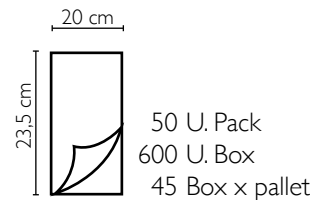

50 U. Pack
600 U. Box
45 Box x pallet

47x40 cm

Servilleta
Serviette
Guardanapos
Napkins

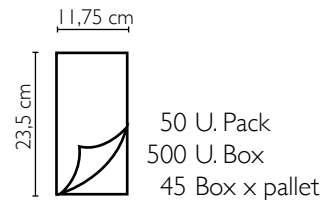

50 U. Pack
500 U. Box
45 Box x pallet

47x47 cm 1/8

Servilleta
Serviette
Guardanapos
Napkins

Mantel / Sets de table / Toalhete / Tablecloths

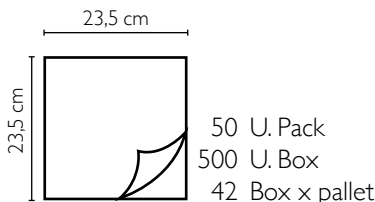

50 U. Pack
500 U. Box
42 Box x pallet

47x47 cm

Servilleta
Serviette
Guardanapos
Napkins

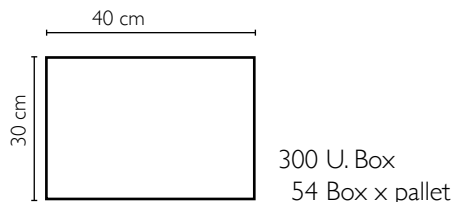

300 U. Box
54 Box x pallet

30x40 cm

Mantel
Sets de table
Toalhete
Tablecloths

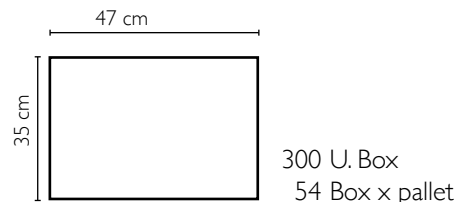

300 U. Box
54 Box x pallet

35x47 cm

Mantel
Sets de table
Toalhete
Tablecloths

Rollo Mantel / Rouleaux de Nappe / Rolos de Toalhas / Tablecloths Rolls

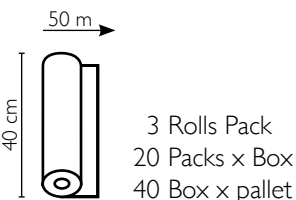

3 Rolls Pack
20 Packs x Box
40 Box x pallet

0,40x50 m

Dueto
Chemins de table
Dueto
Tablecloths Rolls

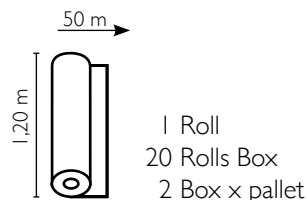

1 Roll
20 Rolls Box
2 Box x pallet

1,20x50 m

Rollo Mantel
Rouleaux de nappe
Rolos de Toalhas
Tablecloths Rolls





Nature

Ecofriendly paper

ES Fabricamos nuestro propio papel Nature con lo que garantizamos la calidad constante del producto y el control de todo el proceso de fabricación. Aprovechamos las fibras de celulosa presentes en los envases de cartón para fabricar productos que ofrecen suavidad y le confieren este característico color. GC Nature te ayuda para crear un ambiente natural y respetuoso con el medio ambiente en tu establecimiento gracias a una amplia gama de productos con tintas compostables.

FR Nous fabriquons notre propre papier Nature. Nous garantissons ainsi la qualité constante du produit et le contrôle de l'ensemble du procédé de fabrication. Nous réutilisons les fibres de ouate présentes dans les emballages carton pour fabriquer des produits qui offrent de la douceur et lui confèrent cette couleur caractéristique. GC Nature vous aide à créer un environnement naturel et respectueux de l'environnement dans votre établissement grâce à une large gamme de produits avec des encres compostables.

PT Fabricamos o nosso próprio papel Nature para garantir a qualidade constante do produto e o controlo de todo o processo de fabrico. Aproveitamos as fibras de celulose presentes nas embalagens de cartão para fabricar produtos que oferecem maciez e que se apresentam nesta cor característica. A GC Nature ajuda-o a criar um ambiente natural e ecológico no seu estabelecimento, graças a uma ampla gama de produtos com tintas compostáveis.



EN We manufacture our own Nature paper, allowing us to guarantee consistent product quality and control of the whole manufacturing process. We use cellulose fibres from cardboard packaging to manufacture products that are soft and have a distinctive natural color. GC Nature helps you to create a natural and environmentally friendly environment in your establishment thanks to a wide range of products with compostable inks.











SERVILLETAS NATURE / SERVIETTES NATURE GUARDANAPOS NATURE / NATURE NAPKINS



T222001

		
	17x17 cm	30x30 cm
	T221099	T221143
Capa Pli Folha Ply	400 U. Pack 16.000 U. Box 24 Box x Pallet	125 U. Pack 4.000 U. Box 28 Box x Pallet

							
	11x20 XS cm	17x20 XL cm	20x20 cm	33x33 cm	30x40 1/6 cm	40x40 1/8 cm	40x40 cm
	T906302	T906303	T972000	T223300	T222002	T221152	T222001
Capas Plis Folhas Plies	360 U. Pack 7.200 U. Box 49 Box x Pallet	200 U. Pack 4.000 U. Box 49 Box x Pallet	100 U. Pack 3.000 U. Box 42 Box x Pallet	100 U. Pack 3.000 U. Box 42 Box x Pallet	75+75 U. Pack 2.400 U. Box 20 Box x Pallet	60+60 U. Pack 2.400 U. Box 20 Box x Pallet	100 U. Pack 2.000 U. Box 20 Box x Pallet

KENYA

Servilleta
Serviette
Guardanapos
Napkins



40x40
cm



T250214

Capas
Plis
Folhas
Plies

100 U. Pack
2.000 U. Box
20 Box x Pallet

KENYA

Mantel
Sets de table
Toalhete
Tablecloths



30x40
cm

48 g.

W250213

2x500 U. Box
72 Box x Pallet

NICE

Servilleta
Serviette
Guardanapos
Napkins

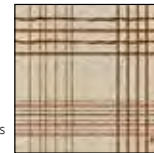





40x40
cm



T250222

Capas
Plis
Folhas
Plies

100 U. Pack
2.000 U. Box
20 Box x Pallet

				
	30x40 cm	35x49 cm	100x100 cm	100x120 cm
48 g.	W240402	W241202	W242200	W242220
	2x500 U. Box 72 Box x Pallet	1.000 U. Box 60 Box x Pallet	3x100 U. Box 22 Box x Pallet	3x100 U. Box 20 Box x Pallet



W250213

SERVILLETAS P&P / SERVIETTES P&P
GUARDANAPOS P&P / P&P NAPKINS



GOMA-CAMPS
ecologic+

100% FIBRAS RECICLADAS · 100% FIBRES RECYCLÉES · 100% FIBRAS RECICLADAS · 100% RECYCLED FIBERS

ES Nuestra marca ecológica de papel tisú reciclado 100% cumple con los requisitos medioambientales más exigentes, ya que cuenta con la Etiqueta Ecológica Europea y el certificado FS .

Apostamos por el reciclado en nuestra gama de mesa. La experiencia que nos avala, tanto como expertos en productos para la mesa, como en la fabricación de reciclado, nos permite lanzar nuevos formatos de servilletas recicladas. Servilletas de gran calidad, suavidad, color y 100% recicladas.

FR Notre marque écologique de papier tissu 100% recyclé répond aux exigences environnementales les plus poussées, car elle possède le label écologique européen et le certificat FS .

Nous misons sur le recyclage dans notre gamme de table. L'expérience qui nous caractérise, tant en tant qu'experts des produits pour la table, que dans la fabrication du recyclé, nous permet de lancer de nouveaux formats de serviettes recyclées. Serviettes de table de haute qualité, douces, colorées et 100% recyclées.

PT A nossa marca ecológica de papel tissue reciclado 100% cumpre com os requisitos meio ambientais mais exigentes, já que conta com a Etiqueta Ecológica Europeia e o certificado FS .

Apostamos pelo reciclado na nossa gama de mesa. A experiência que nos confi ma, tanto como especialistas em produtos de mesa, como na fabricação de reciclado, permite-nos lançar novos formatos de guardanapos reciclados. Guardanapos de grande qualidade, suavidade, cor e 100% reciclados.

EN Our ecological brand of 100% recycled tissue paper keep to the most demanding environmental requirements, due to has the European Ecological Label and the FSC certificat .

We bet on recycling in our table range. The experience that supports us, as highly knowledgeable in table products, as in the manufacture of recycled tissue, allows us to launch new sizes of recycled napkins. High quality, soft, colored and 100% recycled napkins.



The mark of responsible forestry





T222047









T222072



T222073



T222075

						
	T221156	T222044	T222047	T222072	T222073	T222075
Capa	100 U. Pack	100 U. Pack	100 U. Pack	100 U. Pack	100 U. Pack	100 U. Pack
Plis	4.000 U. Box	3.200 U. Box	2.000 U. Box	2.000 U. Box	2.000 U. Box	2.000 U. Box
Folha	28 Box x Pallet	24 Box x Pallet	20 Box x Pallet	20 Box x Pallet	20 Box x Pallet	20 Box x Pallet
Ply						





ES Nuestra gama de mantelería GC incluye prácticos formatos y gran variedad de colores, ideales para todas las necesidades y ocasiones. Mantelos individuales, mantelos en gran formato y rollos en diferentes metrajés y anchos idóneos para cualquier tipo de mesa y de menú.

FR Notre gamme de sets de table, nappes format et rouleaux de nappes GC inclut des formats pratiques et une large gamme de couleurs, idéaux pour tous les besoins et toutes les occasions. Des sets de table, des nappes individuelles, des nappes grand format et des rouleaux de différentes tailles et largeurs adaptés à tout type de table et de menu.

PT A nossa gama de conjuntos de mesa GC inclui práticos formatos e uma grande variedade de cores, ideais para todas as necessidades e ocasiões. Toalhas de mesa individuais, toalhas de mesa em grande formato e rolos em diferentes metragens e larguras ideais para qualquer tipo de mesa e ementa.







EN Our range of GC tablecloths includes practical styles and a wide range of colors ideal for all needs and occasions. Individual tablecloths, large-format tablecloths and rolls of different lengths and widths, ideal for any type of table and menu.

MANTELES BLANCOS / NAPPES BLANCHES / CONJUNTOS DE MESA BRANCOS / WHITE TABLECLOTHS

	 30X40 cm	 30X40 cm	 35X49 cm
37 g.	W240100 1.000 U. Box 72 Box x Pallet	W240106 500 U. Pack 2x500 Box 72 Box x Pallet	W241200 500 U. Pack 1.000 Box 48 Box x Pallet
48 g.	W240400 1000 U. Box 48 Box x Pallet		





W240400,T250220

	 80x80 cm	 80x120 cm	 100x100 cm	 100x100 cm	 100x120 cm	 100x140 cm	 120x120 cm
37 g.	W241600 500 U. Box 36 Box x Pallet	W241800 500 U. Box 26 Box x Pallet	W241912 500 U. Box 25 Box x Pallet	W241905 100 U. Pack 5x100 U. Box 25 Box x Pallet	W242000 500 U. Box 13 Box x Pallet	W241940 400 U. Box 18 Box x Pallet	W242100 500 U. Box 10 Box x Pallet
48 g.		W241820 250 U. Box 26 Box x Pallet	W241990 25x10 U. Box 30 Box x Pallet	W241920 300 U. Box 22 Box x Pallet	W242020 300 U. Box 20 Box x Pallet		W242120 300 U. Box 18 Box x Pallet

MANTELERÍA GC / NAPPAGE GC CONJUNTOS DE MESA GC / GC TABLECLOTHS

DISEÑOS CLASICOS
DESIGNS CLASSIQUES
DESIGN CLASSICS
CLASSIC DESIGNS

48 g.		100x100 cm
		W255050
		W255080
		2x500 U. Box 72 Box x Pallet









W255050,T222081



W250019



W240325,W240315





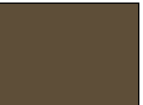
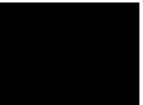

37 g.	Tokyo				Idiomas		Menú				1.000 U. Box 72 Box x Pallet
	30X40 cm	W250076	W250078	W250077	W240315	W240310	W240300	W240325			



MANTELES DE COLORES / NAPPES DE COULEURS / CONJUNTOS DE MESA DE CORES / TABLECLOTH OF COLORS

48 g.	Rojo / Rouge Vermelho / Red	Verde / Vert Verde / Green	Azul / Bleu Azul / Blue	Burdeos / Bordeaux Bordeaux / Burgundy	Cacao / Cacao Cacau / Cocoa	Negro / Noir Preto / Black	500 U. Box 72 Box x Pallet
							
30X40 cm	W250006	W250066	W250016	W250019	W250069	W250068	3x100 U. Box 22 Box x Pallet
100x100 cm	W255001	W255002	W255011	W255013	W255025	W255024	







MANTELES BLANCOS / NAPPES BLANCHES / CONJUNTOS DE MESA BRANCOS / WHITE TABLECLOTHS

37 g.						
	1x10 m	1x25 m	1x100 m	1x100 m	1,20x10 m	1,20x100 m
	R251190	R251191	R251005	R251095	R258990	R251205
	24 Rolls Box 24 Box x Pallet	25 Rolls Box 14 Box x Pallet	25 Rolls Box 2 Box x Pallet	6 Rolls Box 12 Box x Pallet	21 Rolls Box 12 Box x Pallet	25 Rolls Box 2 Box x Pallet

48 g.		
	1x100 m	1,20x100 m
	R251007	R251207
	20 Rolls Box 2 Box x Pallet	20 Rolls Box 2 Box x Pallet

**MANTELES DE COLORES / NAPPES DE COULEURS
CONJUNTOS DE MESA DE CORES / COLORED TABLECLOTH**

	Rojo Rouge Vermelho Red	Verde Vert Verde Green	Azul Bleu Azul Blue	Burdeos Bordeaux Bordeaux Bordeaux	Negro Noir Preto Black	
						
48 g.						
1,20x100 m	R255200	R255232	R255210	R255235	R255236	6 Rolls Box 6 Box x Pallet



GC
GOMA-CAMPS

ES La gama GC, es la gama clásica, supone la base de la categoría de mesa, con gran variedad de formatos, colores y acabados. Dentro de la marca GC, podrás encontrar una amplia gama de productos con una calidad garantizada y certificada

FR La gamme GC est la gamme classique, elle est la base de la catégorie table, avec une grande variété de formats, de couleurs et définitions. Au sein de la marque GC, vous pouvez trouver une large gamme de produits avec une qualité garantie et certifiée.

PT A gama GC, é a gama clássica, supõe a base da categoria de mesa, com grande variedade de formatos, cores e acabados. Dentro da marca GC, poderá encontrar uma ampla gama de produtos com uma qualidade garantida e certificada

EN The GC range is the classic range, it is the basis of the table category, with a wide variety of sizes, colors and finishes. Within the GC brand, you can find a wide range of products with guaranteed and certified quality.



SERVILLETAS P&P / SERVIETTES P&P GUARDANAPOS P&P / P&P NAPKINS









ES Las servilletas Punta&Punta tienen más resistencia y cuerpo que una servilleta dos capas convencional. El acabado P&P se caracteriza por la unión de las dos capas de la servilleta mediante una gota de cola, este tipo de gofrado mejora la apariencia de la servilleta y hace que las capas no se separen. Este sistema aumenta la capacidad de absorción, reduce el consumo y facilita el ahorro.







FR Les serviettes Punta&Punta sont plus résistantes et ont plus de volume qu'une serviette classique à deux plis. La finition P&P se caractérise par le collage de deux plis de la serviette par une goutte de colle. Ce type de gaufrage améliore l'aspect de la serviette et empêche que les plis ne se séparent. Ce système augmente la capacité d'absorption, réduit la consommation et favorise les économies.





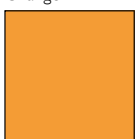
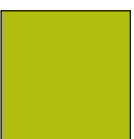



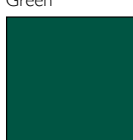

PT Os guardanapos Punta&Punta têm mais resistência e corpo que um guardanapo de duas camadas convencional. O acabamento P&P caracteriza-se pela união das duas folhas do guardanapo mediante uma gota de cola; este tipo de gofragem melhora o aspecto do guardanapo e faz com que as folhas não se separem. Este sistema aumenta a capacidade de absorção, reduz o consumo e facilita a poupança.

EN Punta&Punta napkins are stronger and thicker than traditional two-ply napkins. The P&P finish means that the two layers of the napkin are bonded using a drop of adhesive. This type of embossing improves the appearance of the napkin and stops the plies from separating. This system increases the absorbency of the napkin, reducing consumption and increasing savings.

 Capas Plis Folhas Ply	Burdeos Bordeaux Bordeaux Burgundy	Negro Noir Preto Black		
				
 20x20 cm	T222026	T222027	T222021	100 U. Pack 3.000 U. Box 42 Box x Pallet
 30x40 1/6 cm	T221122	T221124	T221121	75+75 U. Pack 3.000 U. Box 20 Box x Pallet

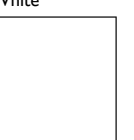

 Capas Plis Folhas Ply	Gris Gris Cinza Gray	Caramel Ivoire Caramelo Caramel	Naranja Orange Laranja Orange	Kiwi Kiwi Kiwi Kiwi	Rojo Rouge Vermelho Red	Turquesa Turquoise Turquesa Turquoise	
							
 40x40 cm	T222178	T222156	T222174	T222176	T222153	T222183	100 U. Pack 2.000 U. Box 20 Box x Pallet

 Capas Plis Folhas Ply	Azul Bleu Azul Blue	Verde Vert Verde Green	Burdeos Bordeaux Bordeaux Burgundy	Cacao Cacao Cacau Cocoa	Negro Noir Preto Black	Blanco Blanc Branco White	Antracita Anthracite Antracite Anthracite	
								
 40x40 cm	T222152	T222159	T222151	T222157	T222154	T222150	T222137	100 U. Pack 2.000 U. Box 20 Box x Pallet
 40x40 1/8 cm	-	-	-	-	T221125	T221129	T221119	60+60 U. Pack 2.400 U. Box 20 Box x Pallet

NICE

ES Con la servilleta Nice P&P conseguirás que tus clientes se sientan como en casa al crear para ellos un ambiente cálido y acogedor en cualquier época del año.

FR Avec la serviette Nice P&P vos clients seront comme à la maison grâce à une ambiance chaleureuse et accueillante à toute période de l'année.

PT Com o guardanapo Nice P&P conseguirá que os seus clientes se sintam como em casa ao criar-lhes um ambiente quente e acolhedor em qualquer época do ano.

EN With the Nice P&P napkin you will be able to create a cozy and welcoming mood, which will make your customers feel like home at any time of the year.



T250221,W255013



T250220,T250221,T250222



T250220,W255011

Textile Natural
ESTILO
Style Têxtil



2
 Capas, Plis
 Folhas, Ply

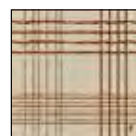
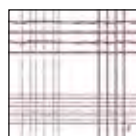
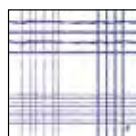

Servilletas
 Serviettes
 Guardanapos
 Napkins



40x40
 cm

T250220

T250221

T250222

100 U. Pack
 2.000 U. Box
 20 Box x Pallet



T250222

TOKYO

ES Cenefa de trazo desigual que proporciona un toque diferenciador a la mesa. Combínalo con el mantel **Tokyo** o con los manteles GC.

FR Une bordure avec un trait irrégulier qui donne une touche différenciatrice aux tables. Combinez-la avec le set de table **Tokyo** ou les nappes GC.

PT Cenefa com traços desiguais que proporciona um toque diferenciador à mesa. Combine-o com a toalha de mesa **Tokyo** ou com as toalhas de mesa GC.

EN Irregular edged balance that lends a different touch to your table. Combine it with the **Tokyo** or GC tablecloths.



T222138, W250076



T222142, W250077



T222139

ServilletasTokyo / Serviettes Tokyo / Guardanapos Tokyo / Tohyo Napkins

	Blanco Blanc Branco White	Ivoire Ivoire Ivoire Ivoire	Rojo Rouge Vermelho Red	Azul Bleu Azul Blue	Verde Vert Verde Green	Burdeos Bordeaux Bordeaux Burgundy	Cacao Cacao Cacau Cocoa	Negro Noir Preto Black
 Capas, Plis Folhas, Ply 40x40 cm								
100 U. Pack 2.000 U. Box 20 Box x Pallet	T222138	T222144	T222141	T222140	T222148	T222139	T222146	T222142

**SERVILLETAS GC / SERVIETTES GC
GUARDANAPOS GC / GC NAPKINS**



ES Las servilletas GC forman nuestra gama de producto más extensa en distintos formatos, colores y calidades. Un producto funcional que combina con la gama de mantelería GC y facilita la creación de ambientes personales dando un toque de color al establecimiento.

FR Les serviettes de table GC forment notre gamme de produits la plus étendue sous différents formats, couleurs et qualités. Un produit fonctionnel qui se combine avec la gamme de nappes GC et permet de créer des ambiances personnelles en donnant une touche de couleur à l'établissement.

PT Os guardanapos GC formam a nossa gama de produto mais extensa em diferentes formatos, cores e qualidades. Um produto funcional que combina com a gama de conjuntos de mesa GC e facilita a criação de ambientes personalizados dando um toque de cor ao seu estabelecimento.

EN GC napkins are our largest range of products in a wide variety of formats, colors and styles. A functional product that can be combined with the GC range of tablecloths to create many different settings, giving a touch of color to your establishment.

SERVILLETAS / SERVIETTES / GUARDANAPOS / NAPKINS

Capa Pli Folha Ply	17X17 cm	17X17 cm	17X17 cm	30x30 cm
	T221077	T941028	T221075	T221131
	400 U. Pack 16.000 U. Box 24 Box x Pallet	200 U. Pack 6.000 U. Box 54 Box x Pallet	10x100 U. Pack 15.000 U. Box 25 Box x Pallet	200 U. Pack 1.000 U. Box 20 Box x Pallet

Capa Pli Folha Ply	17X17 cm	17X17 cm	
	T221097	T221096	
	100 U. Pack 2.000 U. Box 20 Box x Pallet		

	11x20 XS cm	17x20 XL cm	30x30 cm	33x33 cm	40x40 cm	40x40 cm
	T906300	T906301	T222033	T902033	T222040	T222059
Capas Plis Folhas Plies	360 U. Pack 7.200 U. Box 49 Box x Pallet	200 U. Pack 4.000 U. Box 49 Box x Pallet	100 U. Pack 3.200 U. Box 24 Box x Pallet	100 U. Pack 3.000 U. Box 20 Box x Pallet	100 U. Pack 2.400 U. Box 20 Box x Pallet	6x100 U. Pack 4x600 Box 8+8 Box x Pallet



T906300, T224004

	Burdeos Bordeaux Bordeaux Burgundy	Negro Noir Preto Black		
Capas Plis Folhas Plies	40x40 cm	40x40 cm	Capas Plis Folhas Plies	30x30 cm
	T222084	T222088		T223030
	75 U. Pack - 1.800 U. Box 20 Box x Pallet			100 U. Pack 3.000 U. Box 20 Box x Pallet
				T223040
				75 U. Pack 1.800 U. Box 20 Box x Pallet





DECORE SU MESA

ES Los manteles DCR son ideales y aportan distinción, color y funcionalidad a la mesa. Están fabricados con un material resistente y que no se deteriora con la humedad.

DCR está disponible en una amplia gama de colores que al combinarlo con las servilletas GC conseguirás crear diferentes ambientes.

FR Les sets de table et rouleaux de nappe DCR sont idéaux: ils apportent distinction, couleur et fonctionnalité à la table. Ils sont faits d'un matériau résistant qui ne se détériore pas avec l'humidité.

DCR est disponible dans une large gamme de couleurs qui, combinées avec les serviettes GC, créent des ambiances différentes.

PT As toalhas de mesa DCR são ideais e conferem distinção, cor e funcionalidade à mesa. São fabricadas com um material resistente e não se deterioram com a humidade.

DCR está disponível numa vasta gama de cores para permitir a sua combinação com os guardanapos GC e assim criar diferentes ambientes.

EN DCR tablecloths are the ideal way to bring a touch of distinction, color and functionality to your table. They are manufactured with a strong material that does not deteriorate when damp.

DCR is available in a wide range of colors that can be combined with GC napkins to create different environments.

MANTELERÍA DCR / NAPPAGE DCR

CONJUNTOS DE MESA DCR / DCR TABLECLOTHS



R255009

Precorte / Prédécoupe / Pré-corte / Pre-cut

Dueto 0,40x48 m:

Manteles sin dobleces.
Precorte cada 30 cm.
2 en 1, Dueto y Mantel individual 30x40.
Corte limpio y perfecto.
Retractilado y etiquetado unitario.

Et set de table 0,40x48 m :

Nappes sans plis.
Prédécoupage tous les 30 cm
2 en 1, tête à tête et set de table 30x40.
Prédécoupe propre et parfaite.
Rouleau filmé et étiquetage unitaire.

Rolo Dueto 0,40x48 m:

Toalhas de mesa sem vincos.
Pré-corte a cada 30 cm.
2 em 1, Dueto e Toalha de mesa individual 30x40.
Corte limpo e perfeito.
Retratilagem e etiquetagem unitárias.

Dueto roll 0.40 x 48 m:

Tablecloths with no folds
pre-cut every 30 cm.
2-in-1, Dueto and individual tablecloth measuring 30 x 40.
Clean and perfect cut.
Individually shrink-wrapped and labelled.

Caramel
Ivoire
Caramelo
Caramel

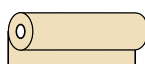

Kiwi
Kiwi
Kiwi
Kiwi



Turquesa
Turquoise
Turquesa
Turquoise



Azul
Bleu
Azul
Blue





Burdeos
Bordeaux
Bordeaux
Bordeaux



Cacao
Cacao
Cacao
Cocoa



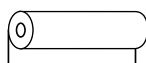

 0,40x48 m	R255013	R255017	R255009	R255012	R255014	R255011
 1,20x50 m	R255064	R255072	R255059	R255061	R255062	R255063

Blanco
Blanc
Branco
White



Negro
Noir
Preto
Black



 0,40x48 m	R255015	R255010	6 Rolls Box 30 Box x Pallet
 1,20x50 m	R255056	R255060	1 Roll Box 20 Box x Pallet



PERSONALIZA TUS SERVIETAS Y MANTELES

En Gomà-Camps te ofrecemos la posibilidad de personalizar tus productos en 4 pasos muy sencillos.

1 Selecciona el producto que necesitas de entre el amplio abanico de opciones que te ofrecemos. Todos nuestros productos personalizables están indicados en el catálogo con el icono de un lápiz.

2 Elige el Color y posición! Te ofrecemos un amplia gama de colores y alternativas de posición con las que podrás personalizar tu producto.

3 Envíanos tu pedido y te mandaremos un boceto para su conÆrmación.

4 Recibe tu pedido.

PERSONNALISEZ VOS SERVIETTES ET VOS NAPPES

Chez Gomà-Camps nous vous offrons la possibilité de personnaliser vos produits en quatre étapes faciles.

1. Choisissez le produit dont vous avez besoin parmi la vaste gamme que nous vous offrons. Tous nos produits personnalisables sont indiqués avec l'icône d'un crayon dans le catalogue.

2. Choisissez la couleur et la position. Nous offrons une large gamme de couleurs et d'alternatives de position pour personnaliser votre produit.

3. Envoyez-nous votre commande et nous vous enverrons un BAT pour conÆrmation.

4. Recevez votre commande.

PERSONALIZE OS SEUS GUARDANAPOS E TOALHAS DE MESA

Na Gomà-Camps oferecemos a possibilidade de personalizar os seus produtos em 4 passos muito simples.

1. Seleccione o produto que necessita de entre o vasto leque de opções que oferecemos. Todos os nossos produtos personalizáveis estão indicados no catálogo com o ícone de um lápis.

2. Escolha a cor e a posição! Oferecemos uma vasta gama de cores e alternativas de posição com as quais poderá personalizar o seu produto.

3. Envie-nos o seu pedido e receberá um esboço para a sua conÆrmação.

4. Receba o seu pedido.

Votre logo

PERSONALISE YOUR NAPKINS AND TABLECLOTHS

Gomà-Camps offers you the possibility of customize your products in 4 easy steps.

1. Select the product you need from the wide range of options we offer you. All our customizable products are marked in the catalogue with a pencil icon.

2. Choose the color and position! we offer you a wide range of colors and position options to personalise your product.

3. Send us your order and we'll send you a design sketch for conÆrmation.

4. Receive your order.

Tintas estándar / Encres standard / Tintas padrão / Standard inks

Pantone Blanco U	Pantone 320 U
Pantone Yellow U	Pantone 3005 U
Pantone 7405 U	Pantone 286 U
Pantone 7410 U	Pantone 280 U
Pantone 021 U	Pantone 241 U
Pantone 182 U	Pantone 2685 U
Pantone 514 U	Pantone 1675 U
Pantone Proces magenta U	Pantone 464 U
Pantone 199 U	Pantone 731 U
Pantone 200 U	Pantone 476 U
Pantone 209 U	Pantone 422 U
Pantone 375 U	Pantone 877 U
Pantone 377 U	Pantone 7545 U
Pantone Green U	Pantone 5483 U
Pantone 3425 U	Pantone 5395 U
Pantone 5753 U	Pantone 447 U
Pantone 297 U	Pantone Black U
Pantone 7466 U	Pantone 871 U

Personaliza tus productos y consigue diferenciarte del resto.

Personnalisez vos produits et différenciez-vous des autres.

Personalize os seus produtos e consiga diferenciar-se.

Personalize your products and stand out from the rest.



Trabajamos con tintas al agua compostables.

Nous travaillons avec des encres à l'eau compostables.

Trabalhamos com tintas à base de água compostáveis.

We work with water-based and compostable inks.



DISPENSADORES DE MESA / DISTRIBUTEURS DE TABLE DISPENSADORES MESA / TABLE DISPENSERS



Dispensadores de Servilletas / Distributeurs de serviettes Dispensador de guardanapos / Napkins dispensers



Dispensador servilletas 30x40
Distributeurs de serviettes 30x40
Dispensador de guardanapos 30x40
Napkin dispensers 30x40

		Dispenser Size
T224009	Plastic Fume	135x203x173

1 U. x Box

Dispensador de servilletas 30x40 en vertical. Facilita la dispensación de servilletas en barras o buffets, en que el comensal se prepara el mismo el Servicio.
Distributeur de serviettes vertical 30x40. Il facilite la distribution des serviettes dans les bars ou buffets, dans lesquels le client se sert lui-même son repas.
Porta-guardanapos vertical 30x40. Facilita a distribuição de guardanapos em bares ou buffets, nos quais o utilizador prepara ele mesmo o serviço.
Vertical 30x40 napkin dispenser. It facilitates the dispensing of napkins in bars or buffets, in which the diner prepares himself the Service.



Dispensador servilletas 17x17
Distributeurs de serviettes 17x17
Dispensador de guardanapos 17x17
Napkin dispensers 17x17

		Dispenser Size
T221069	Metallic / Stainless	100x100x130

25 U. x Box

Dos opciones de dispensador para las servilletas 17x17: en plástico y en metal inoxidable. Ideales tanto para barras como mesas.
Deux options de distributeurs pour les serviettes 17x17: en plastique et en métal inoxydable. Idéal pour les comptoirs et les tables.
Duas opções de dispensador para guardanapos de 17x17: em plástico e em metal inoxidável. Ideais tanto para balcões como mesas.
Two dispensing options for 17 x 17 napkins: in plastic or stainless metal. Ideal for bars and tables.



Dispensador servilletas interplegadas 17x20
 Distributeurs de serviettes enchevêtrées 17x20
 Dispensador de guardanapos folha a folha 17x20
 Dispenser interfolded napkins 17x20

		Dispenser Size
T224004	Plastic	159x191x124

1 U. x Box

Dos modelos de dispensación ideales para las servilletas interplegadas: XL y XS. Aporta control en la dispensación e higiene, ya que las servilletas se encuentran dentro del dispensador y el comensal debe de tirar de una en una para su uso. Una solución de dispensación sostenible ya que reduce el consumo de servilletas.

Deux modèles de distribution idéaux pour les serviettes de table enchevêtrées : XL et XS. Permet de contrôler la distribution et l'hygiène, puisque les serviettes se trouvent à l'intérieur du distributeur et que le convive se doit de les extraire une par une pour pouvoir les utiliser. Une solution de distribution durable car elle réduit la consommation de serviettes.

Dois modelos de dispensação ideais para guardanapos folha a folha: XL e XS. Confere controlo na dispensação e higiene, já que os guardanapos se encontram dentro do dispensador e o cliente precisa extrair um por um para poder utilizá-los. Uma solução de dispensação sustentável, já que reduz o consumo de guardanapos.

Two models of dispensers ideal for napkin sizes XL to XS. Give control on dispensing and hygiene since napkins are already inside the dispenser and the diner has to take them one by one when using. A sustainable dispensing solution that reduces napkins consumption.



Dispensador servilletas interplegadas 11x20
 Distributeurs de serviettes enchevêtrées 11x20
 Dispensador de guardanapos folha a folha 11x20
 Dispenser interfolded napkins 11x20

		Dispenser Size
T224007	Plastic	150x135x150

20 U. x Box

Con este dispensador mejora la presentación y la higiene de las servilletas 20x20 en la barra o en las mesas de tu local.

Avec ce distributeur vous améliorez la présentation et l'hygiène des serviettes 20 x 20 au comptoir ou sur les tables de votre établissement.

Este dispensador melhora a apresentação e a higiene dos guardanapos 20x20 no balcão ao nas mesas do seu estabelecimento.

This dispenser offers improved image and hygiene of 20 x 20 napkins at the bar or for the tables of your establishment.



Dispensador servilletas 20x20
 Distributeurs de serviettes 20x20
 Dispensador de guardanapos 20x20
 Napkin dispenser 20x20

		Dispenser Size
T221027	Methacrylate	110x100x58

15 U. x Box



T224009



T224007



Model Glace



Model Spiga

Celebración

Celebra y crea un ambiente de festividad con nuestra colección de diseños.

Consulte con su delegado de zona, la disponibilidad de modelos en temporada.

Célébrations

Fêtez et créez une atmosphère festive avec notre collection de motifs.

Renseignez-vous auprès de votre délégué commercial pour connaître la disponibilité des modèles en saison.

Celebrações

Celebre o e crie um ambiente de festividade com a nossa coleção de designs.

Consulte com o seu gestor comercial a disponibilidade de modelos sazonais.

Celebration

Celebrate by creating a festive atmosphere with our collection of designs.

Enquiry your comercial for the availability of seasonal styles.



España

(+34) 977 876 802
info@gomacamps.com

France

(+33) 563 358 905
france@fr.gomacamps.com

Portugal

(+351) 249 730 230
portugal@pt.gomacamps.com

Maroc

(+212) 0 5377 17774
maroc@ma.gomacamps.com

International

(+34) 977 876 803
export@gomacamps.com

www.gomacamps.com